

Ray54E

Marine

VHF Radio

Owner's Handbook

Document number: 81232-2

Date: August 2004

About this Handbook

Introduction

This handbook describes the Ray54E fixed VHF marine radio. The Ray54E provides two-way communications on all International marine channels, pre-set private channels, and (if programmed) all US and Canadian and marine channels. The Ray54E includes equipment for Class “D” Digital Selective Calling (DSC).

Conventions Used

Throughout this handbook, the dedicated (labelled) keys are shown in bold capitals (for example: **SCAN/SAVE**). The LCD indicators and functions are shown in normal capitals (for example: TX).

- Operating procedures, which may consist of a single key-press or a sequence of numbered steps, are indicated by an arrow icon shown in the margin.

Technical Accuracy

To the best of our knowledge, the information in this handbook was correct as it went to press. However, our policy of continuous product improvement and updating may change specifications without prior notice. As a result, unavoidable differences between the product and handbook may occur from time to time. Raymarine cannot accept liability for any inaccuracies or omissions it may contain.

For the latest product information visit our website:

www.raymarine.com

Warranty

To register your new Raymarine product, please take a few minutes to fill out the warranty registration card found at the end of this handbook. It is very important that you complete the owner information and return the card to the factory in order to receive full warranty benefits.

Raymarine is a registered trademark of Raymarine Limited.

© Raymarine Limited 2004

Important Information

Maritime Mobile Service Identity (MMSI)

The Ray54E includes equipment for Class “D” Digital Selective Calling (DSC). A nine-digit Maritime Mobile Service Identity (MMSI) number is required to operate the DSC equipment. In some areas, a radio operator licence is required before an MMSI number will be issued. You can request an MMSI number from same agency that issues radio or Ship Radio licences in your area. Once obtained, you can program the MMSI number into your Ray54E as described in this handbook.

Group MMSI ID

A Group ID MMSI number can also be entered for vessels that are part of a group, such as a flotilla or racing fleet, enabling DSC communications within the group.

Automatic Transmitter Identification System (ATIS)

If you purchased your Ray54E to include use on the inland waterways of the contracting governments of the “Regional Arrangement Concerning the Radiotelephone Service on Inland Waterways”—also known as the Basel Agreement¹—your Ray54E will be programmed by your dealer to include Automatic Transmitter Identification System (ATIS) functionality. ATIS includes data at the end of radio transmission that identifies your station. ATIS operation can be turned on or off as needed via the radio’s Menu mode. See *page 79*.

Note: *When ATIS is enabled, certain programming steps have been implemented to protect the integrity of the Basel Agreement, including the blocking of DSC functions when ATIS is active. See Digital Selective Calling (DSC) on page 31 and ATIS Function on page 79.*

Your ATIS ID number is derived from your vessel’s call sign. Your authorized Raymarine dealer can assist you in decoding your ATIS ID number, which you can then program into your Ray54E using the operation described on *page 77*.

1.The Basel Agreement includes Germany, Austria, Belgium, Bulgaria, Croatia, France, Hungary, Luxembourg, Moldova, the Netherlands, Poland, Romania, Russian Federation, the Slovak Republic, Switzerland, the Czech Republic, Ukraine and the Federal Republic of Yugoslavia.

SAFETY NOTICE

Your Raymarine VHF radio generates and radiates radio frequency (RF) electromagnetic energy (EME). This equipment must be installed and operated in accordance with the instructions contained in this handbook. Failure to do so can result in personal injury and/or product malfunction.

CAUTION: Navigation Aid

Although we have designed this product to be accurate and reliable, many factors can affect its performance including equipment failure or defects, environmental conditions, and improper handling or use.

As a result, it should only be used as an aid to navigation and should never replace common sense and navigational judgement. Always maintain a permanent watch so you can respond to situations as they develop.

Antenna Mounting and EME Exposure

For optimal radio performance and minimal human exposure to radio frequency electromagnetic energy, make sure the antenna is:

- connected to the radio before transmitting
- properly mounted
- located where it will be away from people
- located at least 1.5 metres (5 feet) from the radio's main unit

Safe Compass Distance

Safe Compass Distance is 1 meter for a common mechanical compass; other compass types may require greater distances. To be sure, you should locate the radio as far as possible from the compass. Test your compass to verify proper operation while the radio is also operating.

EMC Conformance

All Raymarine equipment and accessories are designed to the best industry standards for use in the recreational marine environment. Their design and manufacture conform to the appropriate Electromagnetic Compatibility (EMC) standards but correct installation and use is required to ensure that performance is not compromised.

Certificate No.

RT044**Raymarine®**

EC Declaration of Conformity

We **Raymarine Limited****Anchorage Park
Portsmouth
Hampshire
England PO3 5TD**

declare, under our sole responsibility, that the products identified in this declaration, and to which this declaration relates, are in conformity with the essential requirements of European Parliament and Council Directive:

1999/5/EC on radio equipment and telecommunication terminal equipment and the mutual recognition of their conformity.

Product Name: **Raymarine RAY 54E VHF Radio with Class "D" DSC**
Product Number(s): **E43024 (White)
E43025 (Black)**

The products have been assessed to Conformity Procedure Annex IV of the Directive and by application of all or part of the following standard(s):

Non-Harmonised Standards(s): **EN 300 698-1, EN 60945, IEC 62238**

The satisfactory assessment of the above, for the following Harmonised Standards, allows:

Full presumption of conformity: **EN 300 698-2, EN 300 698-3, EN 301 843-1,
EN 301 843-2**
General presumption of conformity: **EN 301 025-2, EN 301 025-3**

The assessment is consistent with a Technical Construction File showing conformity with the essential requirements of the Directive and has been reviewed by Notified Body No. 0168

The product is labelled with the CE conformity marking, the identification number of the Notified Body and class identifier.

Signatory: Name **Adil Abbas**
Title **International Compliance Manager**
Company Name **Raymarine Limited**
Company Address **Anchorage Park
Portsmouth, Hampshire
England PO3 5TD**

Signature _____

Date

June 2004

Contents

About this Handbook	iii
Introduction	iii
Conventions Used	iii
Technical Accuracy	iii
Warranty	iii
Important Information	iv
Maritime Mobile Service Identity (MMSI)	iv
Automatic Transmitter Identification System (ATIS)	iv
SAFETY NOTICE	iv
Chapter 1: Introduction	1
1.1 Ray54E Fixed Station VHF Radio	1
1.2 Features	1
Chapter 2: Installation	3
2.1 Unpacking and Inspection	3
Equipment Supplied	3
2.2 Planning the Installation	4
Typical Mounting Methods	4
Flush Mounting	4
2.3 Power Connections	6
2.4 External Speaker Connections	7
2.5 Grounding	7
2.6 NMEA Data	7
2.7 Antenna Connections	8
Antenna Mounting Suggestions	8
Chapter 3: Getting Started	9
3.1 Keypad and Rotary Knobs	9
Microphone Keys	10
Main Unit Rotary Keys	10
Main Unit Push Keys	10
Microphone	11
1. PTT	11
2. UP/DOWN	11
3. 16/PLUS	11
4. HILO	11
Main Unit	11
5. CH	11
6. PWR/VOL	11
7. SQ	11
8. DW/TRI	11

9. CALL/MENU	12
10. HILO/USER	13
11. SCAN / SAVE	13
12. 16/PLUS	14
13. CLEAR	14
14. DISTRESS	14
3.2 LCD Display	14
1. (HI/LO) TX Power	14
2. (TX) Transmitting	14
3. (RX) Receiving	15
4. (LOCAL) Local/Distant Mode	15
5. DSC Message	15
6. ATIS Active	15
7. NO GPS	15
8. Battery Low	15
9. (USER) Favourite Channel Mode	15
10. (SAVED) Memory Mode	15
11. (WX) Weather Channel	15
12. (ALERT) Weather Alert	15
13. (U I C) Channel Set	16
14. (A) Simplex Channel	16
15. (B) Receive-only Channel	16
16. Channel Number	16
17. Dot Matrix Display	16
Chapter 4: General Operations	17
4.1 Turning the Power ON and OFF	17
4.2 Setting the Volume	17
4.3 Setting the Squelch	17
4.4 Setting the Power Output	17
4.5 Setting the Channel	18
On the microphone... ..	18
On the main unit... ..	18
4.6 Selecting a Weather Channel (If Available)	19
Weather Alert Operation (If Available)	20
4.7 Selecting the Priority Channel	20
4.8 Selecting the Secondary Priority (PLUS) Channel	21
Reprograming the Secondary Priority (PLUS) Channel	22
4.9 Transmitting	23
4.10 Using the Scan Modes	23
All Scan	24
Saved (Memory) Scan	24
Priority All Scan	25

Priority Saved Scan	25
4.11 Adding Channels to Memory	26
4.12 Using the Monitor Modes	27
Dual Watch	27
Tri Watch	28
4.13 USER Channel Mode	29
4.14 DSC Call Operation	29
4.15 Menu Mode Operation	30
Chapter 5: Digital Selective Calling (DSC)	31
5.1 DSC Call Function	32
5.2 Individual Calls	34
Making DSC Calls to Coast Stations	34
Transmitting an Individual Call	34
Receiving Individual Calls	37
5.3 Group Calls	38
Transmitting a Group Call	38
Receiving Group Calls	40
5.4 All Ships Calls	42
Transmitting an All Ships Call	42
Receiving an All Ships Call	43
5.5 Distress Calls	45
Sending a Distress Call	45
Undesignated (Quick) Distress Call	46
Designated Distress Call	46
Cancelling a Distress Call Made in Error	48
Receiving a Distress Call	48
Receiving a Distress ACK Sent from a Coast Station	49
Receiving a Distress Relay Sent by Another Station	49
5.6 Position Request	50
Specifying the Target Vessel	50
Retrieving the Last Received Position Data	52
Receiving a Position Request From Another Station	53
5.7 Call Log	53
Making a Call from a Call Log Entry	54
Saving an MMSI ID Number from a Call Log Entry	55
5.8 DSC Distress Log	56
Chapter 6: Menu Settings	57
6.1 Menu Function	57
6.2 DSC Phonebook	59
Adding an Entry	59
Editing an Existing Entry	61
Deleting an Existing Entry	62

6.3	Backlight Adjustment	63
6.4	Contrast Adjustment	63
6.5	GPS/Time Setup	64
	When GPS Information Not Available	64
6.6	Settings	66
	Latitude/Longitude Display	67
	Time Display	67
	Time Offset	68
	Time Format	68
	COG/SOG Display	68
6.7	Radio Setup	69
	Band	69
	Channel (CH) Name	70
	Display Name	70
	CH Info	70
	Deleting a Channel Name Entry	70
	Ring Volume	70
	Key Beep	70
6.8	DSC Setup	71
	My MMSI ID	72
	Group MMSI Setup	73
	Adding a New Group	74
	Editing an Existing Entry	76
	My ATIS ID	77
	ATIS Function	79
	Position Reply	81
	Automatic Channel Changing for Incoming Calls	82
	Procedure When Enabled	82
	Procedure When Disabled	83
6.9	Resetting Factory Defaults	84
Chapter 7: Customer Service		85
7.1	How to Contact Raymarine	85
Appendix A: Specifications		87
Appendix B: Channel List		89
	International Marine VHF Channels & Frequencies.....	89
	European Private Channels and Frequencies	92
	WX Channels (North America only)	92
	U.S. Marine VHF Channels and Frequencies.....	93
	Canadian Marine VHF Channels and Frequencies	96
Appendix C: Glossary		101
	Index	103

Chapter 1: Introduction

1.1 Ray54E Fixed Station VHF Radio

The Ray54E marine VHF radiotelephone is a microprocessor-controlled transceiver that provides reliable simplex (single frequency) and semi-duplex (two frequency) communications. This handbook describes the physical and functional characteristics of the radio.

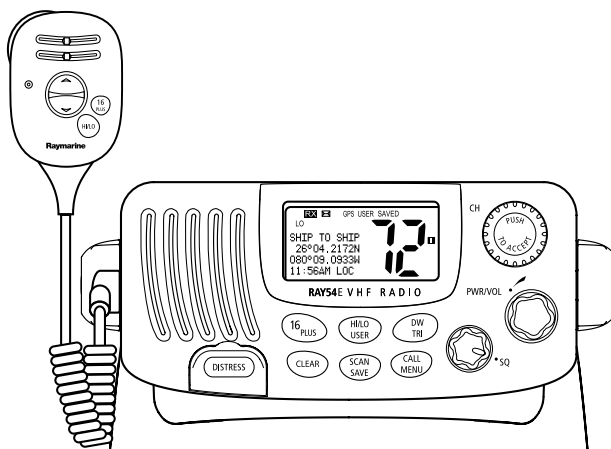

Figure 1-1: Ray54E VHF Radio

The Ray54E provides two-way communications on all International marine channels, pre-set private channels, and (if programmed) all US and Canadian marine and weather channels. Refer to the Frequency Tables in Appendix B, which list all marine VHF channels available in your radio. You should familiarize yourself with these tables to ensure proper channel usage.

1.2 Features

The Ray54E is designed and manufactured to provide ease of operation with excellent reliability. The Ray54E has many enhanced features, including:

- Waterproof to IPX-7 standard
- Anti-glare 2" x 1.5" LCD with 4 x 12 dot matrix display
- Nine (9) brightness and contrast adjustments
- Dedicated key for switching to Priority Channel 16

- Programmable Secondary Priority (PLUS) Channel key
- ATIS operation, if required
- Private Channels (if so licensed)
- All Scan, Memory Scan and 2 Priority Scan functions
- Dual/Tri Watch Monitor modes
- Each channel displays an editable 12-character Channel Name
- Enhanced GPS Position Data gives Latitude and Longitude to 1/10,000 of a minute plus Time, SOG and COG data from any NMEA input
- Automatically distinguishes between calls made to Ship or Coast Stations
- Low and High Voltage detection with alarm
- User Mode provides easy access to favourite channels
- Key Beep volume adjustment (3 levels)

Digital Selective Calling (DSC)

The Ray54E includes equipment for Class “D” Digital Selective Calling (DSC). DSC protocol is a globally applied system used to send and receive digital calls. DSC uses a unique Maritime Mobile Service Identity (MMSI) number to direct DSC calls directly to your radio, much like a telephone number. When the DSC signal is received, the radio quickly switches over to channel 70 and performs the corresponding operation.

Note: *An MMSI number is required to operate the DSC equipment in this radio. You can program the MMSI number yourself one time only using the Menu Operation described in this handbook. See My MMSI ID on page 72.*

The Ray54E includes the following DSC features:

- Separate receiver dedicated to handling DSC Calls on channel 70
- Position Request function sends GPS position data to or receives position data from other stations
- Phonebook for automatically making DSC calls
- Quick Save feature saves incoming DSC Calls and the caller’s associated MMSI number directly into the phonebook
- Quick Call feature sends Individual Calls or Group Calls directly from the phonebook, just like the redial function on a telephone
- Three (3) Group IDs for making DSC Calls only to stations in your group, such as a flotilla or fishing fleet

DSC functions are fully described in *Chapter 5*:

Chapter 2: Installation

2.1 Unpacking and Inspection

Use care when unpacking the unit from the shipping carton to prevent damage to the contents. It is also good practice to save the carton and the interior packing material in the event you must return the unit to the factory.

Equipment Supplied

The following is a list of materials supplied with the Ray54E:

Table 2-1: Supplied Components

Part Number	Description
E43024	Ray54E, White
E43025	Ray54E, Charcoal Gray
81232	Handbook, Ray54E
R49108	Power Cord, Ray54E
R49128	NMEA Cable, Ray54E
R49133	Speaker Cord, Ray54E
R49093	Mounting Yoke for White Ray54E
R49095	Mounting Yoke for Charcoal Ray54E
R49094	Yoke Knob and Spacer for White Ray54E
R49096	Yoke Knob and Spacer for Charcoal Ray54E
R49104	Microphone Bracket for White Ray54E
R49105	Microphone Bracket for Charcoal Ray54E
R49109	Sun Cover, White
R49110	Sun Cover, Charcoal Gray
	Mounting Hardware: Screws (x4) for Mounting Yoke Screws (x2) for Microphone Bracket Screw/Lock Washer (x1) for Grounding

The following is a of optional equipment for the Ray54E:

Table 2-2: Optional Equipment

Part Number	Description
E46034	Flush Mount Kit, A Series VHF Radios

2.2 Planning the Installation

When planning the installation of your Ray54E, consider the following conditions to ensure dependable and trouble-free operation.

Mount the main unit to allow easy access from the location where the boat is normally navigated.

The main unit is designed to be mounted horizontally or vertically on a flat bulkhead. Select a location that is non-metallic, dry, protected, well-ventilated, and free from high operating temperatures and excessive vibration. Provide sufficient space behind the main unit to allow for proper cable connections to the rear panel connectors. Locate the main unit as near as possible to the power source yet as far apart as possible from any devices that may cause interference such as motors, generators, and other on board electronics. The radio should be protected from prolonged direct exposure to rain and salt spray.

The Ray54E is not designed to be mounted in engine compartments. Do not install the radio in a location where there may be flammable vapours (such as in an engine room or compartment, or in a fuel tank bay), water splash or spray from bilges or hatches, where it is at risk from physical damage from heavy items (such as hatch covers, tool boxes, etc.), or where it might be covered by other equipment. Locate the radio at least 1.5 meters from the antenna.

Safe Compass Distance is 1 meter for a common mechanical compass; other compass types may require greater distances. To be sure, you should locate the radio as far as possible from the compass. Test your compass to verify proper operation while the radio is also operating.

Typical Mounting Methods

The Ray54E can be conveniently mounted on a chart table, bulkhead, overhead, or any other desired location. Refer to the following figure for typical mounting methods.

Flush Mounting

In addition to the typical Mounting Methods, the Ray54E may also be flush mounted using the optional E46034 Flush Mount Kit. Instructions for installing the radio using the Flush Mount Kit are included with the kit. These kits are available from your Raymarine dealer.

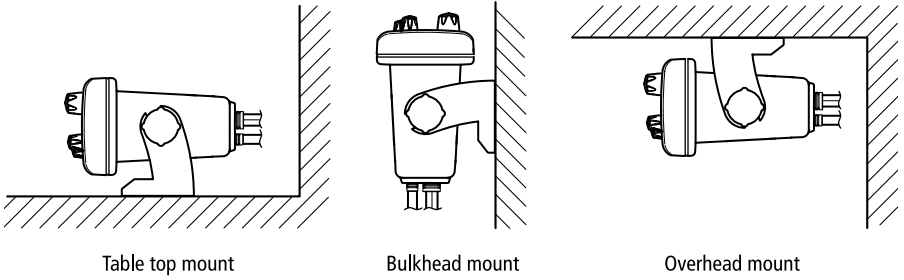

Figure 2-1: Typical Mounting Methods

CAUTION: Make sure there are no hidden electrical wires or other items behind the desired location before proceeding. Check that free access for mounting and cabling is available.

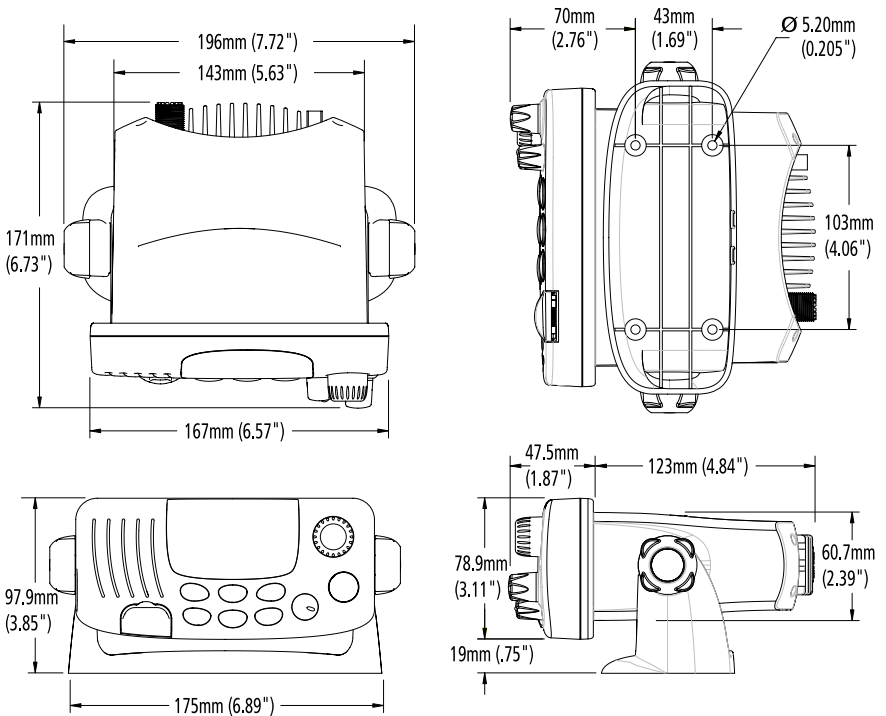

Figure 2-2: Mounting Dimensions

2.3 Power Connections

The red and black power cord provides connections to DC power. The red (+) wire is connected to the positive terminal of the power source and contains a 7 amp in-line fuse. The black (-) wire is connected to the negative (ground) of the power source. Should the power connections be inadvertently reversed, the unit will not power up but no damage will occur. Check the polarity with a VOM (Voltage/Ohm Meter) and reconnect observing correct polarity. If the fuse ever needs replacement, be sure to use the same type and rating.

Connect your Ray54E to the nearest primary source of the boat's DC power. A typical source may be a circuit breaker on the power panel or a fuse block near the unit. When connecting to either of these sources, the circuit breaker or other in-line fuse should be rated at 10 amps.

The power cord should be long enough to reach the DC power source. If additional wire length is required, the cable can be extended by adding more cable as necessary. However, for power cable runs longer than 15 feet, larger wire diameter size should be used to prevent voltage line loss.

To ensure adequate current draw to the equipment, Raymarine recommends that you use lugs to connect the power cable to the DC supply and that the lug connections be both crimped and soldered. The connection terminal should be clean, with no sign of corrosion.

The Ray54E is designed to be operated on a 12 volt (nominal) system. If battery voltage drops below 10.5 VDC (approx), the **Low** icon appears on the LCD (see *page 15*). You should discontinue using the radio if a low voltage condition occurs as performance would be unreliable. If voltage exceeds 16 VDC, the message EXCESSIVE VOLTAGE appears on the dot matrix display and an alarm is sounded. You should immediately disconnect the radio if a high voltage condition occurs as the unit could become damaged.

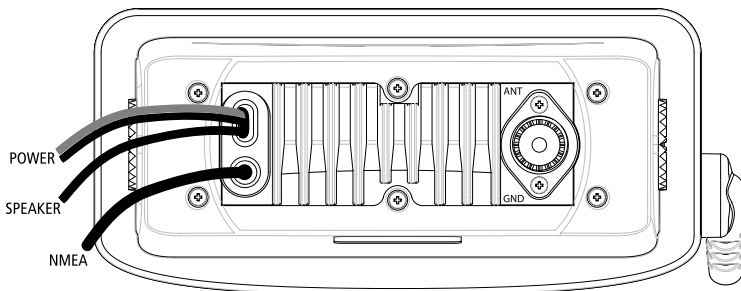

Figure 2-3: Wiring Connections

2.4 External Speaker Connections

Located just below the power cord is a cable for connection to an optional external speaker. Connect the white(+) wire and black (-) wire to the speaker observing polarity as it is marked on the speaker. When connected, the external speaker will function simultaneously with the internal speaker.

2.5 Grounding

While special grounding is not generally required for VHF radiotelephone installations, it is good marine practice to properly ground all electronic equipment to the boat's earth ground system. The Ray54E can be connected to ground by installing the supplied screw and lock washer in the threaded hole labelled GND on the main unit's rear panel just below the antenna jack. Then attach a wire from this screw to the nearest ship's earth ground connection point. The recommended wire to be used for such grounding is #10 AWG.

2.6 NMEA Data

The Ray54E accepts NMEA 0183 (V1.5) data from a position determining device (such as a GPS) to provide the Latitude and Longitude position information that is transmitted during a DSC Distress Call.

When valid NMEA signal is detected, the GPS indicator appears on the LCD. When no valid NMEA signal is detected, the NO GPS indicator appears.

Connect the NMEA OUT + and NMEA OUT - signals from the positioning device to the NMEA IN + (yellow) and NMEA IN - (green) wires in the radio's NMEA cable.

An example of how to connect the NMEA cables and power supply using a suitable connector block is shown in the diagram below. For specific instructions how to connect your particular GPS, please refer to the handbook that came with that device.

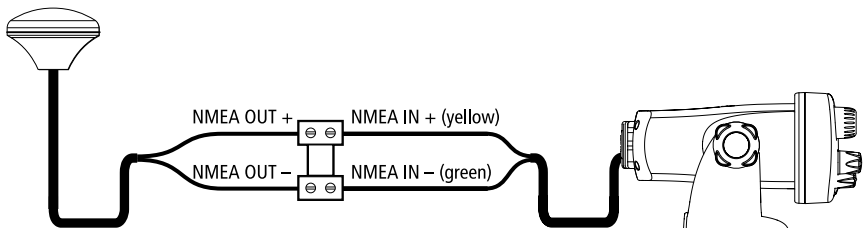

Figure 2-4: GPS Wiring

2.7 Antenna Connections

The coaxial VHF antenna cable connects to the Ray54E antenna jack on the rear panel using a PL259 VHF type connector. The antenna cable length can be critical to performance. If you are uncertain, contact a professional installer or call Raymarine Product Support. If a longer cable length is required, RG-8x (50 ohm) marine coaxial cable or equivalent cable can be used for runs up to a maximum of 50 feet. If the distance required is even greater, Raymarine recommends using low loss RG-213 or equivalent cable for the entire run to avoid excessive losses in power output.

If the antenna RF connector is likely to be exposed to the marine environment, a protective coating of grease (Dow Corning DC-4 or similar) can be applied to the connector before connecting it to the radio. Any other extensions or adapters in the cable run should also be protected by silicon grease and then wrapped with a waterproofing tape.

Antenna Mounting Suggestions

Mounting the VHF antenna properly is very important because it will directly affect the performance of your VHF radio. Use a VHF antenna designed for marine vessels.

Since VHF transmission is essentially line-of-sight, mount the antenna at a location on the vessel that is free of obstruction to obtain maximum range.

If you must extend the length of the coaxial cable between the antenna and the radio, use a coaxial cable designed for the least amount of power loss over the entire cable length.

Antenna Mounting and EME Exposure

For optimal radio performance and minimal human exposure to radio frequency electromagnetic energy, make sure the antenna is:

- connected to the radio before transmitting
- properly mounted
- located where it will be away from people
- located at least 1.5 metres (5 feet) from the radio

Chapter 3: Getting Started

3.1 Keypad and Rotary Knobs

Several of the keys on the front panel of the main unit serve multiple purposes. For the most part, the function indicated on the first line of the key is accessed by pressing and releasing that key. The function indicated on the second line of the key is accessed by pressing and holding the key for three seconds.

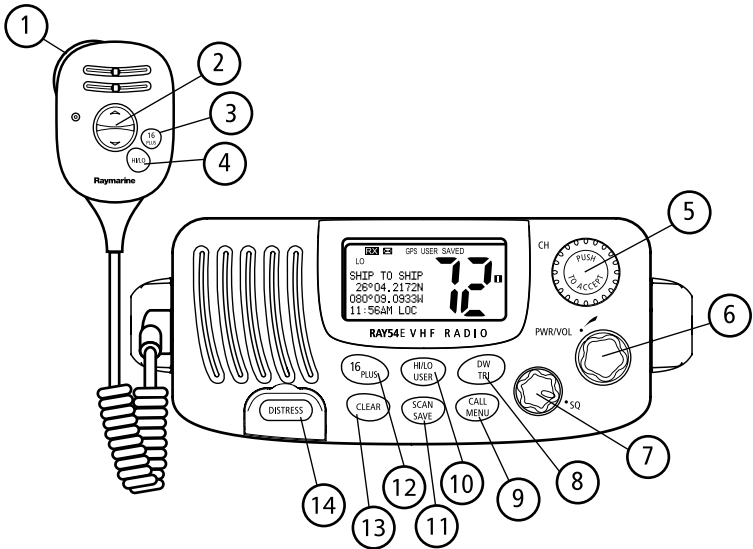

Figure 3-1: Ray54E Keys Layout

Microphone Keys

Key Name	Press & Release (<3 sec.)	Press & Hold (>3 sec.)
1. PTT	Push-to-Talk	Push-to-Talk
2. UP/DOWN	Channel increment/decrement and navigating menu item selections	Rapid channel change and navigating menu item selections
3. 16/PLUS	Switch between the Priority and Working Channels	Switches to Secondary Priority (PLUS) channel; If already tuned to the PLUS channel, programs a new PLUS channel.
4. HI/LO	TX Power High/Low and ACCEPT key for menu item selections	TX Power High/Low and ACCEPT key for menu item selections

Main Unit Rotary Keys

Key Name	Function
5. CH/PUSH	Rotate to increment/decrement channels or navigate menu item selections
6. PWR/VOL	Power radio ON / OFF and adjust volume level
7. SQ	Adjust squelch threshold level

Main Unit Push Keys

Key Name	Press & Release (<3 sec.)	Press & Hold (>3 sec.)
5. CH/PUSH	ACCEPT menu item selections	ACCEPT menu item selections
8. DW/TRI	Dual Watch Mode	Tri Watch Mode
9. CALL/MENU	Activate DSC functions	Activate Menu functions
10. HL/USER	TX Power High/Low	USER (Saved Memory Channel) Mode
11. SCAN/SAVE	Scan ON/OFF	SAVE/DELETE channel to/from memory
12.16/PLUS	Switch between the Priority and Working Channels	Switches to Secondary Priority (PLUS) channel; If already tuned to the PLUS channel, programs a new PLUS channel.
13.CLEAR	Cancel function	Weather Channel Mode, if so programmed
14. DISTRESS	Designate Distress Type	Make Distress Call

Microphone



1. PTT

Press this Push-to-Talk key to transmit.

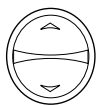

2. UP/DOWN

Use the arrow keys to change the active channel number. Press and hold for rapid channel changing. You can also use these keys to scroll through DSC Call and Menu Mode options and make item selections.



3. 16/PLUS

Use this key to switch to the priority channel or to change the value of the Secondary Priority (PLUS) Channel.



4. HI/LO

Use this key to toggle the transmit power from HIGH to LOW. You can also use it to accept DSC Call and Menu Mode selections.

Main Unit



5. CH

Rotate this knob to change the current channel number and to change values in Menu mode or during programming. Press the knob to enter values selected in Menu mode or during programming.



6. PWR/VOL

Use this knob to turn the radio ON and OFF and to set the volume.



7. SQ

Use this knob to set the squelch threshold, which cuts off the receiver when the signal is too weak for reception of anything but noise.



8. DW/TRI

Press and release this key to select Dual Watch mode, which monitors the current working channel and CH 16 in cycle. Press and hold to select Tri Watch, which monitors CH 16, the current working channel and the channel you have set as the Secondary Priority (PLUS) Channel in cycle. See *Section 4.12*.



9. CALL/MENU

Press and release this key to select to enter DSC Call Mode, which is used for making DSC Calls and viewing the DSC Call Logs and the DSC Call Phonebook.

A Maritime Mobile Service Identity (MMSI) number is required to operate the DSC equipment in this radio. This number directs DSC calls directly to your radio, much like a telephone number. You can program the MMSI number yourself one time only using the Menu Operation described in *Section 6.8, DSC Setup*. Otherwise, your Raymarine dealer can program or change the number for you.

If the MMSI number has not yet programmed, the message DSC IS NOT OPERATIONAL...PLEASE ENTER MMSI ID is displayed in the dot matrix display when you press and release **CALL/MENU**.

DSC Call menu structure is outlined in the following drawing. Full details on DSC call operation are described in *Chapter 5*:

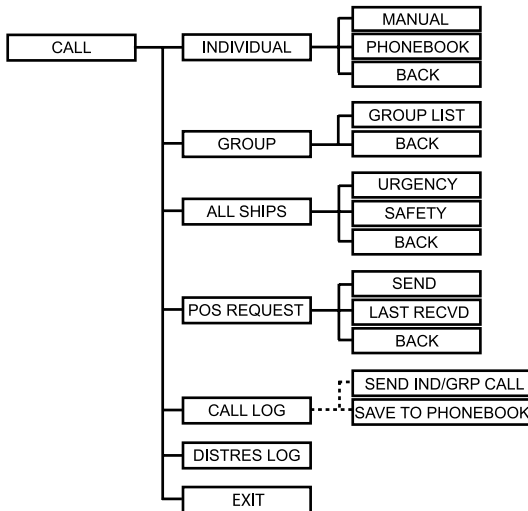

Press and hold **CALL/MENU** to select Menu Mode, which is used to set up the radio. The menu structure is outlined in the following drawing. Menu operations are fully described in *Chapter 6*:

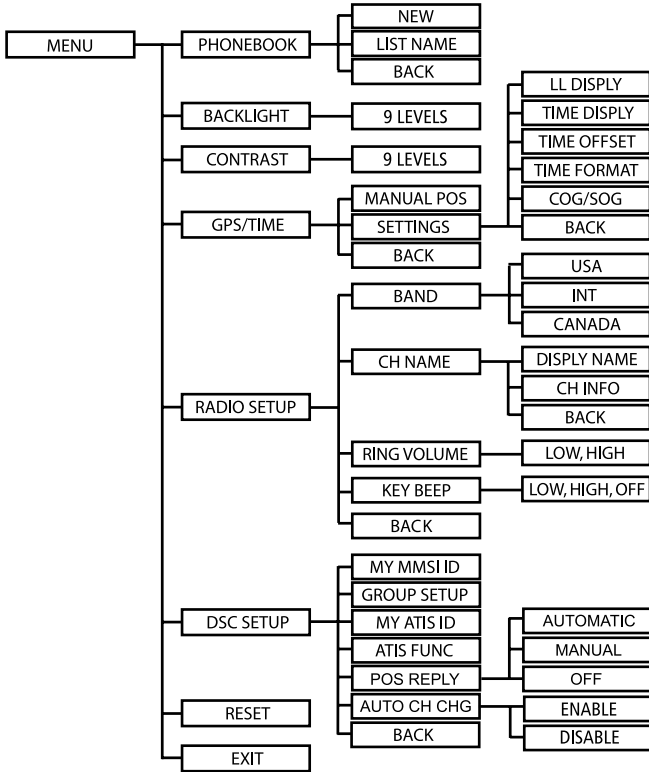

10. HI/LO USER

Press and release this key to toggle the transmit power from HIGH to LOW. Press and hold to select User Channel Mode, which displays only the channels that you have saved to memory. User Mode is described in *Section 4.13*.



11. SCAN / SAVE

Press and release this key to enter one of the Scan Modes, which are described in *Section 4.10*. Press and hold to enter a channel into the radio's memory. This function is described in *Section 4.11*.

16
PLUS

12. 16/PLUS

Use this key to switch to the priority channel or to change the value of the Secondary Priority (PLUS) Channel.

CLEAR

13. CLEAR

Press and release to terminate a function and return to the last-used channel. Press and hold to select the Weather mode (if available).

DISTRESS

14. DISTRESS

Push down the spring-loaded cover and press this key to make a DSC Distress Call. Instructions for making a Distress Call are described in *Section 5.5*.

3.2 LCD Display

The following describes the functional characters on the Ray54E's LCD.

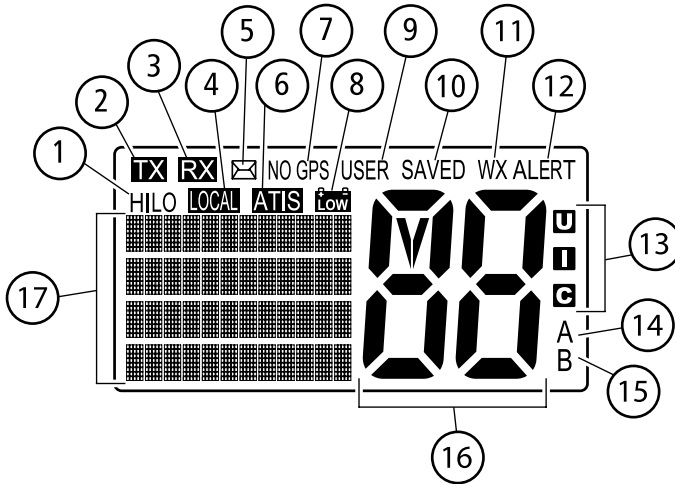

Figure 3-2: Ray54E LCD Layout

1. (HI/LO) TX Power

Indicates whether transmit power is set for 25 watts (HI) or 1 watt (LO).

2. (TX) Transmitting

Indicates the PTT is being pressed and the radio is transmitting.

3. (RX) Receiving

Indicates that the radio is receiving a radio signal.

4. (LOCAL) Local/Distant Mode

Indicates the radio is in Local Reception mode, which decreases receiver sensitivity in high traffic areas to decrease unwanted reception. Only available in Ray54 (North American) model.

5. DSC Message

Indicates the radio has received a DSC Call. Details of the call can be viewed in the DSC log. See *Section 5.8*.

6. ATIS Active

Indicates ATIS transmission is enabled.

7. NO GPS

When GPS appears, positional data is available. When NO GPS appears, the radio is not receiving positional data.

8. Battery Low

Indicates vessel battery voltage is below 10.5 VDC, which is the lowest voltage at which the radio can be reliably operated.

9. (USER) Favourite Channel Mode

Indicates the radio is in User Mode. User Mode displays only the channels that you have saved to memory, enabling you to easily scan your favourite channels while bypassing unwanted or seldom-used channels.

10. (SAVED) Memory Mode

Indicates the current channel has been saved in memory. Appears during Saved Scan mode. Only saved channels are scanned during USER mode.

11. (WX) Weather Channel

Weather channel mode is active. US and Canada only.

12. (ALERT) Weather Alert

Monitoring for weather alert broadcasts. US and Canada only.

13. (U I C) Channel Set

Indicates which channel set is selected: **US**, **I**nternational or **C**anadian.

Note: *Special licensing is required to receive the US and Canadian channel sets.*

14. (A) Simplex Channel

Indicates that the currently-selected channel is simplex; you transmit and receive on the same frequency. Used with US and Canadian channels only.

15. (B) Receive-only Channel

Indicates that you cannot transmit on the currently-selected channel; it is receive-only. Used with Canadian channels only.

16. Channel Number

Displays the current channel number.

17. Dot Matrix Display

Indicates radio functions or special conditions. The type of information displayed depends on the situation. *Figure 3-3* demonstrates a typical screen in normal operating mode. The screen is different when sending/receiving a DSC Call (*see Chapter 5:*) or setting up a Menu item (*see Chapter 6:*).

Note: *In the following sample:*

- (1) *The Channel Name is editable (see page 70).*
- (2) *Valid position data received from a GPS or manually entered (see page 64).*
- (3) *Last line may contain COG/SOG data instead of time (see page 68).*

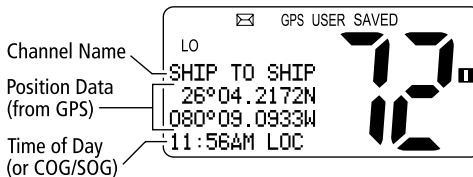

Figure 3-3: Typical Dot Matrix Display Data

Chapter 4: General Operations

4.1 Turning the Power ON and OFF

Turn the **PWR/VOL** knob clockwise until it clicks.

When the unit powers up in Normal mode it:

1. Beeps, illuminates the backlight at full brightness, and displays all segments and indicators for 2 seconds.
2. Displays the software version number on the dot matrix display.
3. Recalls the last CH number, TX power settings and operation mode.
If no last-used setting data exists, goes to CH 16 and high TX Power.

When GPS Data is available, extended position data is also displayed with the offset time on the dot matrix display. This information will be displayed when display option for the position and time is enabled on the Menu. See *Section 6.5*.

To turn the unit OFF, rotate the Volume knob completely counter clockwise until it clicks.

4.2 Setting the Volume

Adjust the **PWR/VOL** knob to control the loudspeaker volume level. Turn clockwise to increase the volume; counter clockwise to decrease the volume.

Note: *Key press beep volume is also controlled by the VOL level.*

4.3 Setting the Squelch

The Squelch circuit sets the threshold for cutting off the receiver when the signal is too weak for reception of anything but noise.

To properly set the squelch, rotate the **SQ** knob counter clockwise until audio is heard. Then rotate clockwise until background noise disappears.

4.4 Setting the Power Output

HI/LO
USER

The choice of power output is dependent upon the distance of transmission and transmitting conditions. International Regulations state you must use the minimum power possible for satisfactory communication.

Press and release the **HL/USER** key on the main unit or microphone to toggle the TX power from **LOW** (1 watt) to **HIGH** (25 watts). The corresponding LO or HI indicator appears on the LCD.

As a part of marine communications courtesy, initial contact should always be attempted using low power. You should switch to high power only when contact can not be made on low power in emergency situations.

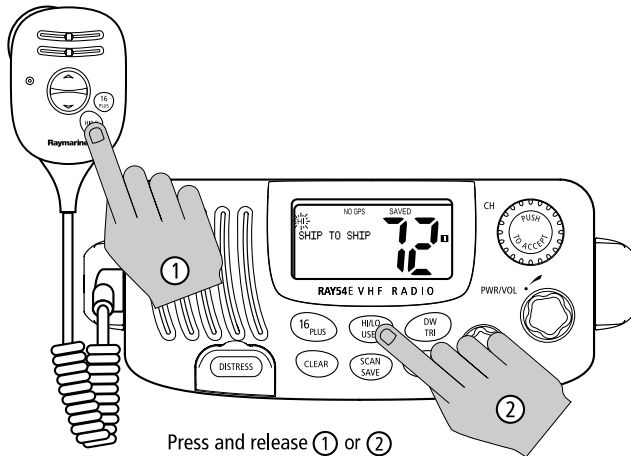

Note: Some channels are limited by regulation to be low power only. If the HILO operation request is denied, an error tone beeps.

4.5 Setting the Channel

On the microphone...

Press and release the UP arrow to increment the channel number.

Press and release the DOWN arrow to decrement the channel.

Press and hold either key for rapid channel scrolling.

On the main unit...

Rotate the **CH** knob clockwise to increment the channel number.

Rotate the **CH** knob counter clockwise to decrement the channel number.

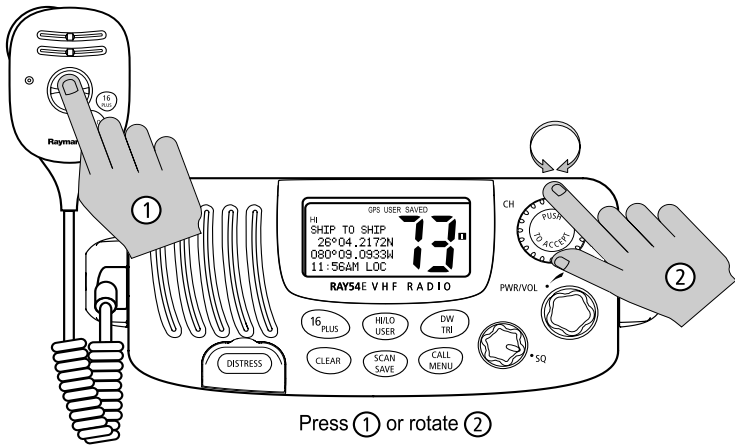

Press ① or rotate ②

4.6 Selecting a Weather Channel (If Available)



The US National Oceanic and Atmospheric Administration (NOAA) broadcasts continuous weather reports and severe weather alerts, as needed. If so equipped, your Ray54E is programmed to receive 10 weather channels and sound an alarm if a weather alert is received.

Press and hold the **CLEAR** key to enter Weather mode.



Press and hold

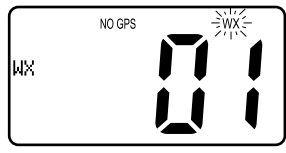

The WX indicator appears on the LCD. Rotate the **CH** knob to select from channels WX01 through WX10.

Press and release the **CLEAR** key again to return to normal operation.

Note:

- 1. WX broadcasts can only be heard in the US and Canada.
- 2. The Ray54E can receive these broadcasts only if the unit has been upgraded by the distributor to use WX Channels.
- 3. During Weather mode, the PTT, HILO/USER, SCAN/SAVE and DW/TRI keys are disabled and an error beep sounds if pressed.

Weather Alert Operation (If Available)

Weather Alert is toggled ON and OFF by pressing and holding **CLEAR** key in the weather mode. The ALERT indicator illuminates.

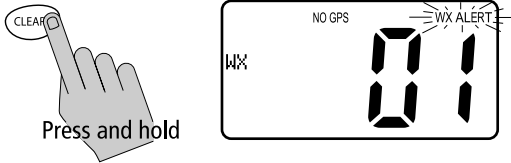

When Weather Alert function is enabled and the radio is tuned to the normal working channel, the last-used weather channel is checked every four minutes for weather alert tone. If the alert tone is detected, the WX and ALERT indicators flash and an alarm sounds.

The radio automatically turns to the currently-monitored WX channel where the weather alert has been detected. The alert is detected in all modes of operation (Standby, Dual and Tri Watch, Scan, etc.)

Note: *The Ray54E can receive weather alert broadcasts in the US or Canada only if the unit has been programmed by the distributor to use WX Channels.*

4.7 Selecting the Priority Channel

16
PLUS

The Ray54E provides you with a dedicated key for switching to the Priority Channel 16.

If not already tuned to the Priority Channel 16, **press and release** the **16/PLUS** key to switch to CH16 at high power.

PRIORITY CH appears in the dot matrix display.

If already on CH 16, **press and release** the **16/PLUS** to return to the last-used working channel.

Note: *When the priority channel is selected, it is always set to HIGH transmit power. You may reduce power if desired by pressing the HI/LO key.*

The **16/PLUS** key also can be used to cancel all modes and switch to CH 16.

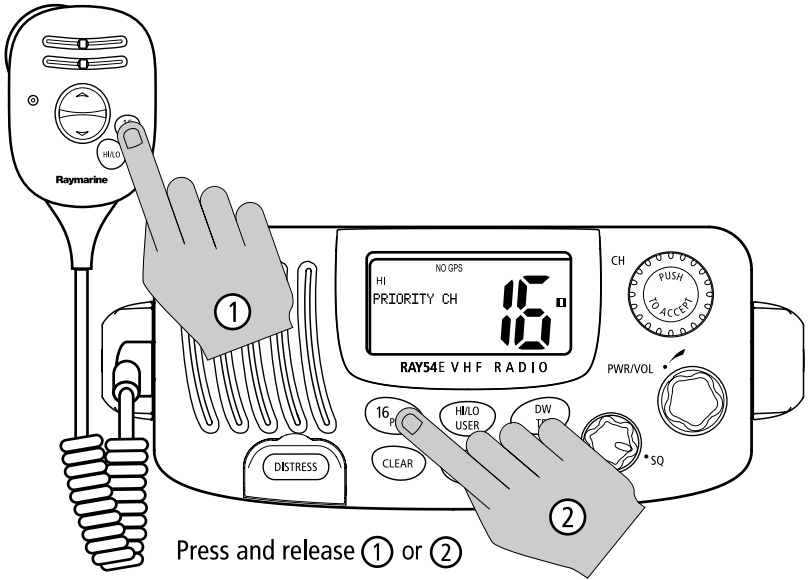

Note: When you press the 16/PLUS key, the radio always switches to HIGH power. You can use the HL/USER key to change to LOW power.

4.8 Selecting the Secondary Priority (PLUS) Channel

16 PLUS

The Ray54E enables you to program the **16/PLUS** key to store a Secondary Priority or Favourite (PLUS) Channel. The default is CH 9.

If on a working channel, **press and hold** the **16/PLUS** for greater than 3 seconds to switch to the Secondary Priority (PLUS) Channel at high power. The default is CH 9.

PRIORITY CH appears in the dot matrix display.

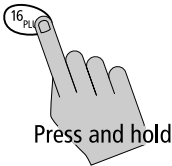

If on primary Priority CH16, **press and hold** the **16/PLUS** for greater 3 seconds to switch to the Secondary Priority (PLUS) Channel at HI power. The default is CH 9.

If already on the Secondary Priority (PLUS) Channel, **press and release** the **16/PLUS** key to switch to Priority Channel 16 at high power.

Reprogramming the Secondary Priority (PLUS) Channel

1. **Press and hold** the **16/PLUS** key for greater 3 seconds to switch to the Secondary Priority (PLUS) Channel.
2. **Press and hold** the **16/PLUS** key for greater 3 seconds again to switch to Reprogram mode. The current Secondary Priority (PLUS) Channel flashes.
3. Change the channel number with the **CH** key.
4. **Push** the **CH** key to ACCEPT the new Secondary Priority (PLUS) selection. An alert tone sounds to indicate that the Secondary Priority (PLUS) Channel has been changed.

Note: During the reprogramming of the Secondary Priority (PLUS) Channel, the PTT and DW/TRI keys are disabled and an error beep sounds if pressed.

STEP 1

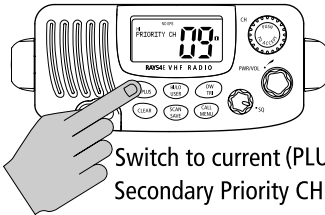

Switch to current (PLUS) Secondary Priority CH

STEP 2

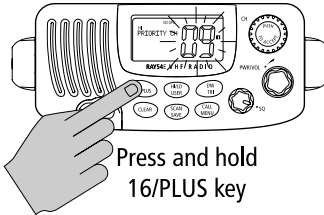

Press and hold 16/PLUS key

STEP 3

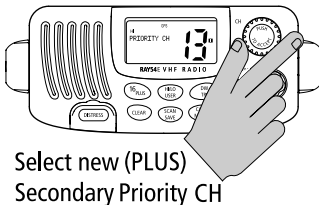

Select new (PLUS) Secondary Priority CH

STEP 4

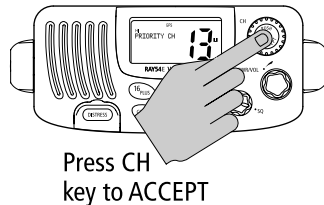

Press CH key to ACCEPT

4.9 Transmitting



Press and hold the Push-to-Talk (**PTT**) key on the microphone to transmit on the selected channel, then release to receive. The TX indicator appears during transmission.

Note: *International regulations and good communications practice dictate that you not interfere with other communications. Before transmitting, listen to make sure the channel is clear.*

The radio is equipped with a timeout timer in the event of a stuck key. After **PTT** has been held continuously for 5 minutes, transmission is discontinued and the radio automatically returns to receive mode. An Error beep is emitted 10 seconds before the time out is triggered and TX flashes on the display until **PTT** is released.

The TX time out timer is reset once the **PTT** key is released.

Note: *If the current channel is receive-only, an alert tone sounds when PTT is pressed, indicating such a transmission is not permitted.*

4.10 Using the Scan Modes



The Ray54E is equipped with four types of scan options: All Scan, Saved (Memory) Scan, Priority All Scan and Priority Saved Scan. If there are no channels in memory, the default is All Scan.

This function automatically searches for broadcasting channels. If a transmission is received, the scan stops on the receiving channel as long as it is present. If the signal is lost for five seconds, the radio resumes scanning.

During the Scan Modes:

- Press the microphone Channel UP/DOWN keys or rotate the **CH** knob on the main unit to change the scan direction. UP (CH key)/clockwise (CH knob) increments the channel while DOWN (CH key) /counter clockwise (CH knob) decrements it.
- Press and release **SCAN/SAVE** to terminate the SCAN mode.
- Press and release **CLEAR** to terminate the SCAN mode.
- Press **16/PLUS** to terminate the SCAN mode and tune to the Priority Channel.
- **DW/TRI** and **HILO/USER** keys are disabled.

Note: *Scan modes are disabled when the ATIS operation is active.*

All Scan

Press and release the **SCAN/SAVE** key when no channels are stored in memory to activate the All Scan function.



ALL SCAN appears on the dot matrix display.

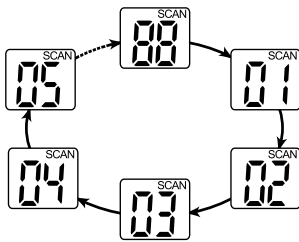

In All Scan mode, all channels in the channel set are scanned in sequence, assuming no channels have been stored in memory. After the last channel number has been scanned, the cycle repeats.

All Scan is demonstrated in the figure to the left.

Saved (Memory) Scan

Press and release the **SCAN/SAVE** key when there is at least one channel in memory to activate the Saved Scan function.



SAVED SCAN appears on the dot matrix display.

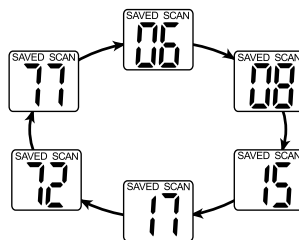

In Saved Scan mode, only the channels that have been saved in memory are scanned in sequence. After the last saved channel number has been scanned, the cycle repeats.

Saved Scan is demonstrated in the figure to the left.

Priority All Scan



Press and hold the **SCAN/SAVE** key while All Scan is active to initiate Priority Scan.

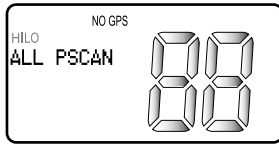

ALL PSCAN appears on the dot matrix display.

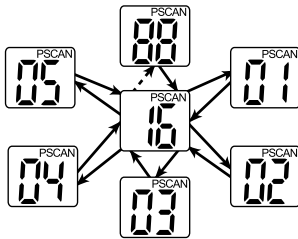

Priority Scan searches for activity on all channels but alternates scanning the Priority Channel 16 after each channel.

Priority Scan is demonstrated in the figure to the left.

Priority Saved Scan

Press and hold the **SCAN/SAVE** key while Saved Scan is active to initiate Priority Saved Scan.

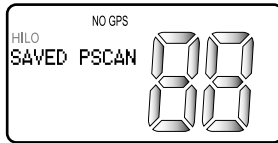

SAVED PSCAN appears on the dot matrix display.

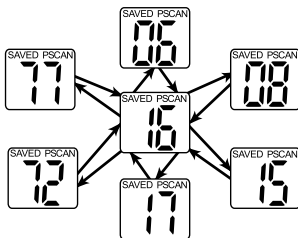

Priority Saved Scan is much like Priority Scan except that the radio alternates searching for activity on the Priority Channel 16 and the channels stored in memory.

Priority Saved Scan is demonstrated in the figure to the left.

Press and hold **SCAN/SAVE** for 3 seconds to exit Priority/Priority Saved Scan and return to All/Memory Scan.

Press and release the **CLEAR** key to exit Priority/Priority Saved Scan and return to the last-used channel.

4.11 Adding Channels to Memory

SCAN
SAVE

The Ray54E can store any channel (including Private Channels). The stored channels are the ones scanned in the Saved (Memory) Scan mode.

► To Add Channels to Memory

1. During normal operation mode, use the **CH** knob to select the desired channel for programming.
2. Press and hold the **SCAN/SAVE** key for 3 seconds.

STEP 1

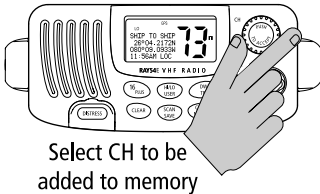

Select CH to be added to memory

STEP 2

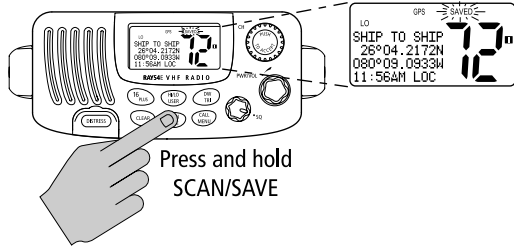

Press and hold SCAN/SAVE

The **SAVED** icon appears to indicate the current channel has been saved in memory. Any number of channels can be saved as memory channels.

► To delete channels from memory

1. During the normal mode, use the **CH** knob to select the channel to be deleted.
2. Press and hold the **SCAN/SAVE** key for 3 seconds.

The selected channel is deleted from memory.

To view the channels set in memory, switch to **USER** mode, as described in *Section 4.13, USER Channel Mode*.

4.12 Using the Monitor Modes



The Watch Modes monitor the programmed Priority Channel and other user-selected channel(s). The watch is halted when activity is detected on a monitored channel. The Ray54E is equipped with 2 types of monitor operations: Dual Watch and Tri Watch.

Note: *Monitor modes are disabled when the ATIS operation is active.*

Dual Watch

Press and release the **DW/TRI** key to activate the Dual Watch mode.



DUAL CH16 appears in the dot matrix display.

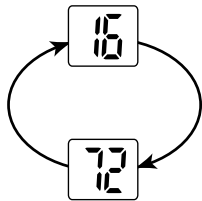

Dual Watch monitors the current working channel and Channel 16 in cycle.

Dual Watch is demonstrated in the figure to the left; the sample working channel is CH 72.

Press and release the **DW/TRI** key to terminate Dual Watch and return to the previous working channel.

Press and hold the **DW/TRI** key to terminate Dual Watch mode and go into Tri Watch mode.

Press and release the **CLEAR** key to terminate Dual Watch mode and return to the last-used channel.

Press and release the **16/PLUS** key to terminate Dual Watch mode and switch to the Priority Channel.

Note: *During Dual Watch mode, the SCAN/SAVE, USER and CH keys are inactive and sounds an error beep if pressed.*

Tri Watch

Press and hold the **DW/TRI** key for 3 seconds to activate Tri Watch mode.



TRI CH16 09 appears on the dot matrix display.

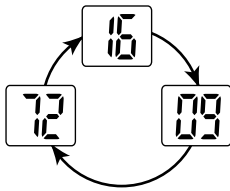

Tri Watch monitors in cycle channel 16, the current working channel and the channel you have set as the Secondary Priority (PLUS) Channel.

Tri Watch is demonstrated in the figure to the left; the sample working channel is channel 72.

Press and release the **DW/TRI** key to terminate Tri Watch and return to the previous working channel.

Press and release the **16/PLUS** key to terminate Tri Watch mode and switch to the Priority Channel.

Press and release the **CLEAR** key to terminate Tri Watch mode and return to the last-used channel.

Note: *During Tri Watch Mode, the SCAN/SAVE, USER and CH keys are inactive and an error beep sounds if pressed.*

4.13 USER Channel Mode



Press and hold the **HL/USER** key while in normal operation mode to enter User Mode. The **USER** and **SAVED** indicators appear.

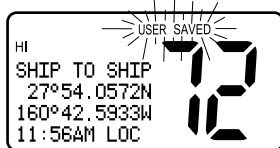

User Channel Mode displays only the channels that you have saved to memory, which enables you to easily use your favourite channels while bypassing unwanted or seldom-used channels during a scan.

Note: *The procedure for saving a channel to memory is outlined in Section 4.11, Adding Channels to Memory.*

While in User Mode the following operations can be performed:

- **Press and release** the **SCAN/SAVE** key to start Memory Scan mode.
- **Press and hold** the **SCAN/SAVE** key to delete the current channel from memory list.
- Press **16/PLUS** to end User mode and switch to the Priority Channel.

Press and release the **CLEAR** key to quit User mode and return to the last-used working channel.

Press and hold the **HL/USER** key for 3 seconds to quit User mode and return to the last-used working channel.

Note: *You cannot switch Channel Sets while in User Mode.*

4.14 DSC Call Operation



Press and release the **CALL/MENU** key while in normal operation mode to enter Call Mode.

DSC Call mode is fully described in *Chapter 5*:

4.15 Menu Mode Operation



Press and hold the **CALL/MENU** key while in normal operation mode to enter Menu Mode.

Menu mode is fully described in *Chapter 6*:

Chapter 5: Digital Selective Calling (DSC)

The Ray54E includes equipment for Class “D” Digital Selective Calling (DSC). DSC protocol is a globally applied system used to send and receive digital calls. DSC uses a unique Maritime Mobile Service Identity (MMSI) number to direct DSC calls directly to your radio, much like a telephone number. When the DSC signal is received, the radio quickly switches over to channel 70 and performs the corresponding operation.

Note: *An MMSI number is required to operate the DSC equipment in this radio. You can program the MMSI number yourself one time only using the Menu Operation described in this handbook. Otherwise, your Raymarine dealer can program or change the number for you.*

The Ray54E includes a separate dedicated receiver just for DSC communications on channel 70. When a DSC call is received, the Ray54E automatically responds based on the type of call. When receiving a DSC call from another vessel or a coast station, an alert sounds and DSC data appears in the LCD—such as time of a call, the caller and the type and priority of a call.

The Ray54E can make the following type of DSC calls:

- **INDIVIDUAL** (routine) Calls are made to a specific station identified by its MMSI number. See *page 34*.
- **GROUP** (routine) Calls send transmissions that are only received by radios that share a common Group MMSI number. See *page 38*.
- **ALL SHIPS** Calls send out a message to all vessels within range. See *page 42*. The Ray54E can make two different types of All Ships calls:
 1. **SAFETY** Calls for advisory alerts
—or—
 2. **URGENCY** when the assistance is required but the situation is not serious enough for a Distress Call
- **DISTRESS** Calls send your vessel’s position and time information to other ships and shore stations, along with (optionally) the nature of your Distress situation. See *page 45*.
- **POSITION REQUEST** calls enable you to request GPS position information from any station for which an MMSI number is known. You can also send out your position to others.

Note: *If you purchased your Ray54E to include use on the inland waterways of the contracting governments of the “Regional Arrangement Concerning the Radiotelephone Service on Inland Waterways”—also known as the Basel Agreement—your Ray54E will be programmed by your dealer to include Automatic Transmitter Identification System (ATIS) functionality.*

If ATIS has been enabled, certain programming steps have been implemented to protect the integrity of this agreement, including the blocking of DSC functions when ATIS is active. See ATIS Function on page 79.

5.1 DSC Call Function

CALL
MENU

DSC Call Mode is used to initiate DSC Individual, Group, All Ships, Distress and Position Request calls and to access the DSC Call Logs and Phonebook.

The channel remains unchanged and you can perform normal TX operation. DSC mode is exited when transmitting.

Press and release the **CALL/MENU** key while in normal operation mode to enter DSC Call Mode.

Note: Distress calls are made using the **DISTRESS** key.

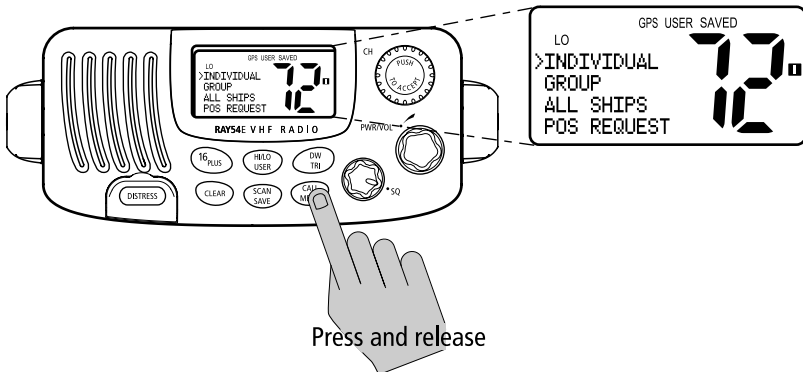

The Ray54E's DSC Call type and structure are as follows:

DSC Call Type	Description
INDIVIDUAL	Makes a ROUTINE DSC call to a specific station identified by its MMSI number.
GROUP	Sends transmissions that are only received by radios that share a common Group MMSI number. Up to 3 Group MMSI numbers can be stored and called.
ALL SHIPS	Sends out a message to all ships within range that you need assistance but the situation is not serious enough for a Distress Call. All Ships calls should only be used if hailing for assistance on channel 16 fails. There are two types of All Ships Calls: SAFETY for advisory alerts and URGENCY for assistance when life is not in immediate danger.

DSC Call Type	Description
DISTRESS	Sends out the position and time information from the input NMEA data along with your MMSI number. This digital information lets other ships and shore stations equipped with appropriate DSC equipment know where you are and that you are in a Distress situation.
POSITION REQUEST	This option enables you to request GPS position information from any vessel for which an MMSI number is known. You can specify the target vessel either by selecting it from your MMSI phonebook or by manually entering its MMSI number. You can also be requested to send out your position to someone else.
RX CALL LOG	A list of all received DSC Call types (except Distress calls) by number and time of call. The log maintains up to 20 calls; the earliest call is stored at the end of the list. After more than 20 calls have been received, the call at the end of the list is automatically overwritten. NOTE: You can place a call directly from the DSC Call Log to the station that is currently displayed. You can also add the displayed station to the DSC Phonebook.
DISTRESS LOG	Lists all stored Distress Calls by number and time of call. The log maintains up to 10 calls; the earliest call is stored at the end of the list. After more than 10 Distress Calls have been received, the call at the end of the list is automatically overwritten. An Individual call can be placed to the selected MMSI/NAME in the log. NOTE: Received Distress Relay calls are also stored in the Distress Log.

Using the Microphone Keys to Make Selections

The examples in this chapter describe how to make menu and character selections using the **CH** knob on the main unit. However, you can also press the microphone **UP/ DOWN** keys to make selections, and then press the microphone **HI/LO** key to accept.

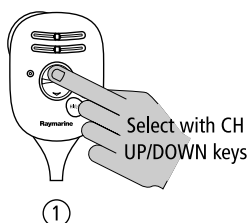

Note: To conform with regulations of the Basel Agreement for radiotelephone service on inland waterways, DSC functions are disabled when ATIS is active. Please see ATIS Function on page 79.

5.2 Individual Calls

The Ray54E can make Individual Routine calls.

Making DSC Calls to Coast Stations

The examples in this handbook illustrate making DSC calls to Ship Stations. However, the procedures for making Individual Calls to a Coast Station are different. Calls to a Ship Station require that you enter a subsequent working channel chosen from a pre-programmed list offered to you by the Ray54E. Calls to a Coast Station remove this step from the operating procedures. The Coast Station controls and indicates the subsequent working channel within its acknowledgement.

The Ray54E automatically detects the correct procedures for you based on the type of MMSI number you enter manually or with or the phonebook. If “00” is detected as the first two characters of the MMSI, Coast Station procedures are implemented automatically.

Note: *When making a call to a coast station, you will not be asked to select a working channel because that will be provided by the coast station.*

Transmitting an Individual Call

To make an Individual Call to a ship or coast station, you must select the specific MMSI number to contact and the working channel to be used for the call. The MMSI ID can be entered manually or selected from a Phonebook list of preprogrammed numbers specified using the MENU function.

INDIVIDUAL

1. **Press and release** the **CALL/MENU** key to enter the DSC menu. The arrow is pointing to INDIVIDUAL.

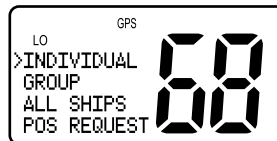

2. Push the **CH** knob to select INDIVIDUAL. The Individual menu appears, which displays the Phonebook entries you have saved and <MANUAL> for manual number entry.

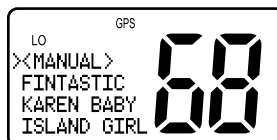

3. Rotate the **CH** knob until the arrow points to the desired individual name.



If using MANUAL MMSI ID entry:

Enter the MMSI number using the **CH** knob. Rotate the **CH** knob to select each character and then push in the **CH** knob to accept. The next position to be modified is indicated by a blinking underline. A full description of manual character entry can be found in *Adding an Entry on page 59*.

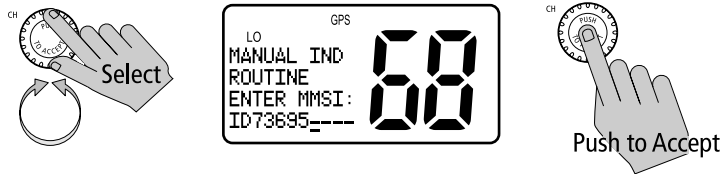

4. Push in the **CH** knob to select the desired individual name/MMSI ID.



5. Rotate the **CH** knob to select the working channel to be used for the Individual Call.

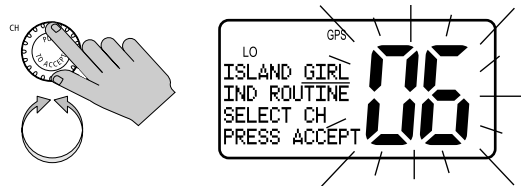

Note: *Individual Calls to a Coast Station remove this step from the operating procedures. The Coast Station controls and indicates the subsequent working channel within its acknowledgement.*

6. Push in the **CH** knob to accept the selection.



7. Push **CH** knob again to send the Individual Call.
The Individual Call is transmitted on channel 70, and then the radio tunes to the original channel and waits for acknowledgement. During this period you are still able to receive calls.

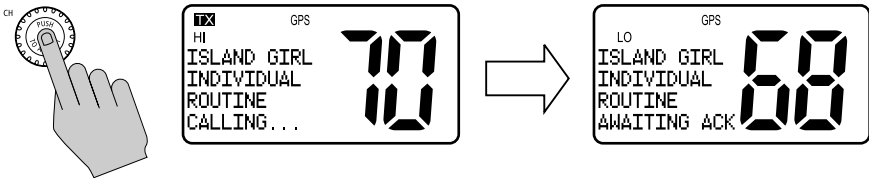

Note: Pressing **PTT** at any time before an **ACK** is received cancels the Individual Call.

When the acknowledgement is received, the Ray54E automatically switches to the selected working channel and sounds a DSC Call alert ring. Press any key to mute the alert ring. It shuts off automatically after two minutes.

8. Press **PTT** to communicate on the specified channel.

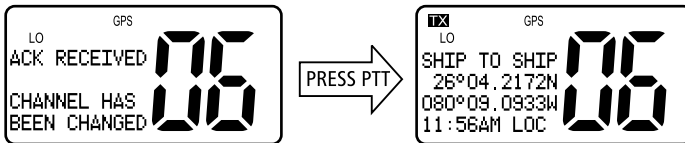

If no acknowledgement is received within 3 minutes, the radio prompts you to resend the call.

If you do nothing for 2 minutes, the Individual Call is cancelled and the radio reverts to the original channel.

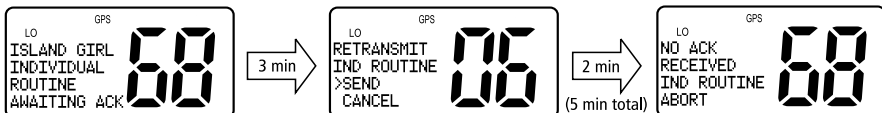

Receiving Individual Calls

INDIVIDUAL

When an Individual Call is received, the radio sounds an alert tone and displays the type of call, the name or MMSI number (if the caller’s MMSI number has not been programmed into your Phonebook) of the caller and the time the call was initiated. When an Individual Call from a station is received, the radio may also ask you to send an acknowledge (ACK) back to the caller. You are prompted to accept or decline the call.

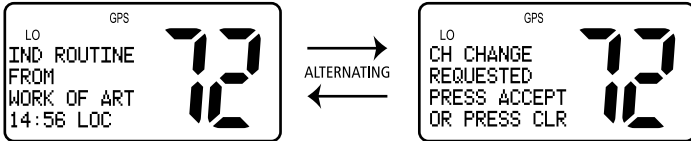

► To silence the alert tone:

Press any key. Automatic cancellation takes place after 2 minutes.

► To cancel the mode without sending ACK:

Press the **CLEAR** key. The alert tone is muted, the Individual Call is interrupted and the normal screen appears on the display.

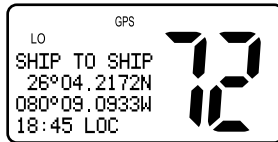

► To accept the Individual Call:

Push the **CH** knob. The tone is muted (if you have not already pressed another key) and an acknowledge (if requested) is sent to the originating station.

The LCD indicates a change of working channels has been made.

For Routine Calls, the channel changes to the one designated by the caller. For Safety and Urgency Calls, the radio automatically switches to channel 16.

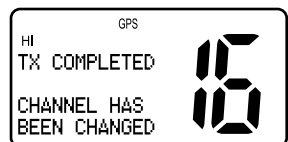
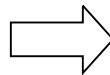
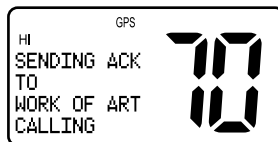

If the caller requests that you change to an unsupported working channel the message **INVALID CHANNEL** appears on the LCD. If an acknowledge is sent, the originating station is notified you were **UNABLE TO COMPLY** with the channel change request.

- Notes:**
- (1) *The DSC Call data is stored in the first available slot in the DSC Call Log, regardless of whether the call is acknowledged.*
 - (2) *Pressing the 16/PLUS key cancels the channel change request and tunes the radio to channel 16.*
 - (3) *If 5 minutes elapse before the call is acknowledged or rejected, the radio automatically declines the incoming Individual Call.*
 - (4) *To conform with inland waterways regulations of the Basel Agreement, DSC functions are disabled when ATIS is active.*

5.3 Group Calls

The Group Call feature sends transmissions that are only received by radios that share a common Group MMSI number, such as a flotilla or racing fleet.

The Ray54E sends Group Routine calls. As with any DSC operation, the Group Call is made on channel 70.

Transmitting a Group Call

To call another vessel in the group, you must select the Group MMSI number to contact and the working channel to be used for the Group Call. The Group MMSI number is selected from a Phonebook list of preprogrammed numbers specified using the Menu function. Up to three Group ID numbers can be stored.

GROUP

1. **Press and release** the **CALL/MENU** key to enter the DSC menu. The arrow is pointing to **INDIVIDUAL**.

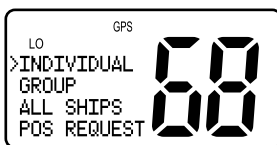

2. Rotate the **CH** knob until the arrow points to **GROUP**.

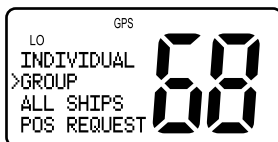
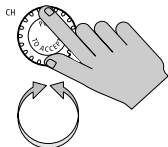

3. Push in the **CH** knob to select GROUP. The Group Call menu appears, which displays the Group entries you have saved.

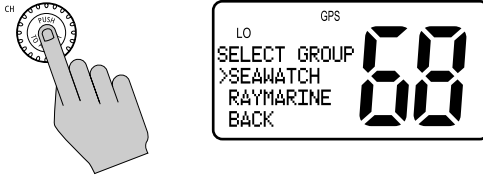

Note: Only the Group IDs that have been programmed into memory appear in the list. If you have not yet programmed any groups into memory, the message NO GROUP IN MEMORY appears. See page 73 for instructions on entering Group ID numbers.

4. Rotate the **CH** knob until the arrow points to the desired Group name.



5. Push the **CH** knob to select the desired Group.



6. Rotate the **CH** knob to select the working channel to be used for the Group Call.

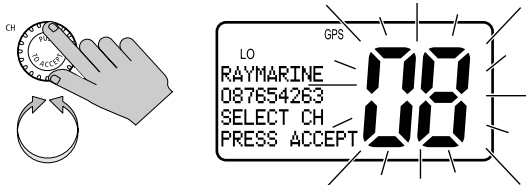

7. Push in the **CH** knob to accept the selection.



- Push the **CH** knob again to send the Group Call.
The Group Call is transmitted on channel 70, and then the radio tunes to the designated working channel to be used for the Group Call.

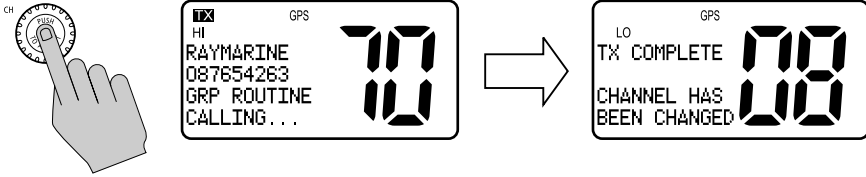

- Press **PTT** to communicate on the specified channel.

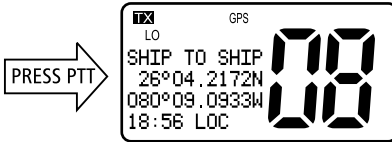

Receiving Group Calls

GROUP

The Ray54E can receive Group Routine Calls from anyone in your prearranged group.

When a Group Call is received, an alert tone sounds and the LCD alternates screens displaying the group name and MMSI ID of the station initiating the call and that a change of working channels is being requested.

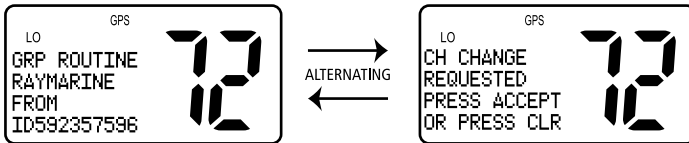

► **To silence the alert tone:**

Press any key. Automatic cancellation takes place after 2 minutes.

► **To ignore the Group Call:**

Press the **CLEAR** key. The alert tone is muted, the Group Call is interrupted and the normal screen appears on the display.

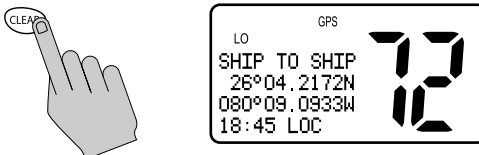

► To accept the Group Call:

Push the **CH** knob. The alert tone is muted (if you have not already pressed another key). The LCD indicates that the channel has been changed to the one designated by the caller.

If the caller requests that you change to an unsupported working channel the message **INVALID CHANNEL** appears on the LCD. The radio is unable to comply with the channel change request but the call is registered in the Call Log.

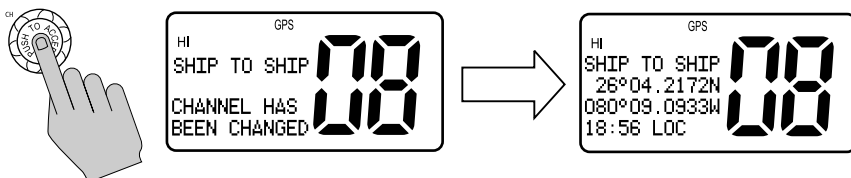

No acknowledgement is sent to the caller. You can establish voice communications on the channel shown in the LCD by pressing the **PTT** key.

- Notes:**
- (1) *DSC Call data is stored in the first available slot in the Call Log.*
 - (2) *Pressing the 16/PLUS key cancels the channel change request and tunes the radio to channel 16.*
 - (3) *If 5 minutes elapse before the Group Call is accepted or rejected, the radio automatically declines the call and the radio reverts to the original channel.*
 - (4) *To conform with regulations of the Basel Agreement for radiotelephone service on inland waterways, DSC functions are disabled when ATIS is active. See ATIS Function on page 79.*

5.4 All Ships Calls

An All Ships Call sends out a message to all ships within range that you need to advise of a hazardous situation or that you require assistance but the situation is not serious enough for a Distress Call.

The Ray54E can make All Ships Safety Calls for advisory alerts and Urgency Calls when assistance is required but life is not in danger. For example, you might send a Safety Call to warn others there is a large floating object that may be a hazard to navigation. A sample Urgency Call might be that you have an illness or an accident on board.

The All Ships Call is made on channel 70, and then the radio automatically switches to channel 16 at high power for voice communications.

Transmitting an All Ships Call

ALL SHIPS

1. Press and release the **CALL/MENU** key to enter the DSC menu. The arrow is pointing to **INDIVIDUAL**.



2. Rotate the **CH** knob until the arrow points to **ALL SHIPS**.

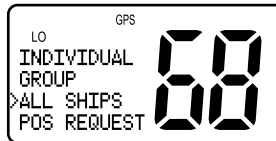
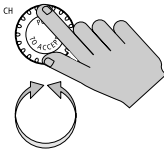

3. Push in the **CH** knob to select **ALL SHIPS**. The All Ships menu appears, which displays the categories from which you can select.

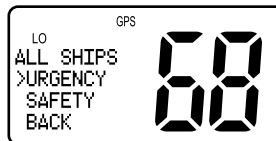

4. Rotate the **CH** knob to select URGENCY or SAFETY.



5. Press the **CH** knob again to send the call.



6. Push **CH** one more time to reconfirm the All Ships Call.

The call is transmitted on channel 70, and then the radio tunes to channel 16 at high power.

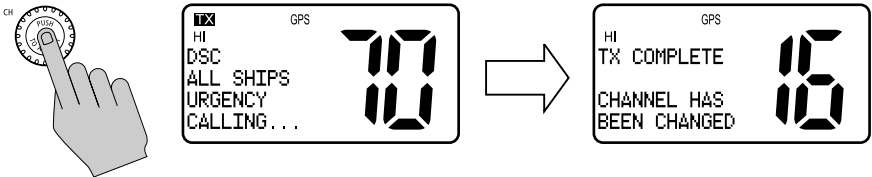

7. Press **PTT** to communicate on the channel 16.



Receiving an All Ships Call

ALL SHIPS

When an All Ships Call is received, the radio sounds an alert tone and displays the type of call, the name or MMSI number (if the caller's MMSI number has not been programmed into your Phonebook) of the caller and the time the All Ships Call was initiated. You are prompted to accept or decline the call. For Urgency Calls, the prompt appears only if you have disabled automatic channel changing (*see page 82*).

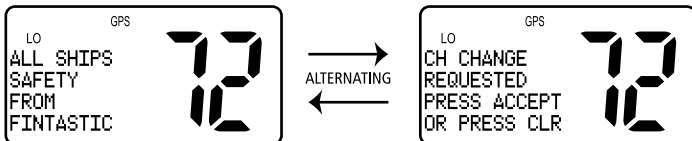

► **To silence the alert tone:**

Press any key. Automatic alert tone cancellation takes place after 2 minutes.

► **To decline the All Ships Call:**

Press the **CLEAR** key. The alert tone is muted, the All Ships Call is interrupted and the normal screen appears on the display.

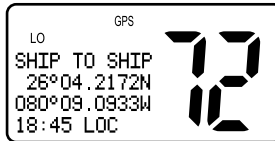

► **To accept the All Ships Call:**

Push the **CH** knob. The alert tone is muted (if you have not already pressed another key) and the radio switches to channel 16.

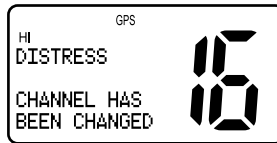

If the caller requests changing to an unsupported working channel, **INVALID CHANNEL** appears on the LCD. The radio is unable to comply with the channel change request but the call is registered in the Call Log.

- Notes:**
- (1) *For All Ships Urgency Calls, the AUTO CH CHG option (see page 82) determines whether your radio automatically switches to channel 16 to receive the call or instead prompts you to manually accept or decline the channel change.*
 - (2) *Pressing the 16/PLUS key cancels the channel change request and tunes the radio to channel 16.*
 - (3) *If 5 minutes elapse before the All Ships Call is acknowledged or rejected, the radio automatically declines the incoming call and the radio reverts to the original channel.*
 - (4) *DSC call data is stored in the first available slot in the Call Log, regardless of whether the call is acknowledged.*
 - (5) *To conform with regulations of the Basel Agreement for radiotelephone service on inland waterways, DSC functions are disabled when ATIS is active. See ATIS Function on page 79.*

5.5 Distress Calls

For a Distress Call transmission, the Ray54E takes the position and time information from the input NMEA data along with your MMSI and converts it into a digital “packet”. When transmitted, this digital information lets other ships and shore stations equipped with appropriate DSC equipment know where you are and that you are in a Distress situation.

Your call can specify the nature of the Distress (designated call) or not (undesignated call). When you make a Designated Distress Call, you can select from the following types:

- UNDESIG (Undesignated)
- FIRE
- FLOODING
- COLLISION
- GROUNDING
- LISTING
- SINKING
- ADRIFT
- ABANDONING (Abandoning Ship)
- PIRACY
- MANOVERBD (Man Overboard)

Sending a Distress Call

DISTRESS

Open the spring-loaded door on the front panel of the main unit.

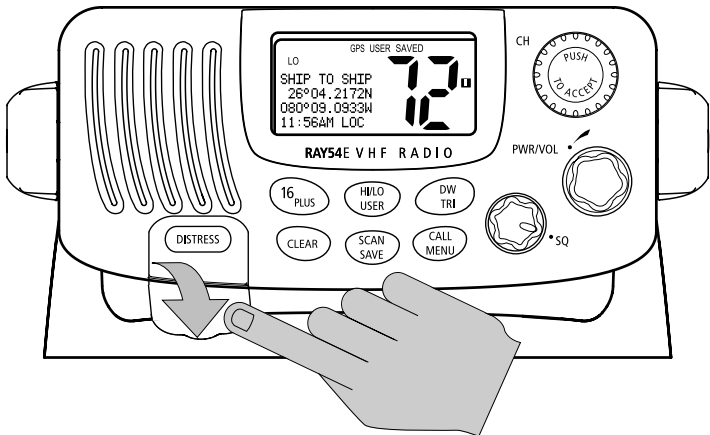

Note: To conform with regulations of the Basel Agreement for radiotelephone service on inland waterways, DSC functions are disabled when ATIS is active. See ATIS Function on page 79.

Undesignated (Quick) Distress Call

1. **Press and hold** the red **DISTRESS** key for 3 seconds to initiate the call. During this time, the radio beeps, the display flashes and a timer counts down 3...2...1.



—or—

Designated Distress Call

1. **Press and release** the red **DISTRESS** key. The Distress Call screen appears.

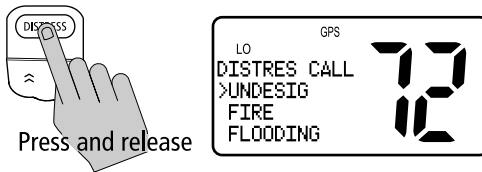

2. Rotate the **CH** knob until the arrow points to the type of Distress you wish to designate.



3. Push in the **CH** knob to select that type of Distress.



4. **Press and hold** the **DISTRESS** key for 3 seconds to initiate the call. During this time, the radio beeps, the display flashes and a timer counts down 3...2...1.



To cancel the Distress Call: release the **DISTRESS** key before the countdown has completed.

After the 3 second countdown is completed, the call is sent and the radio waits for acknowledgement. The display stops flashing and the alarm sounds continuously until muted or an ACK is received.

To mute the alarm: press **CLEAR**.

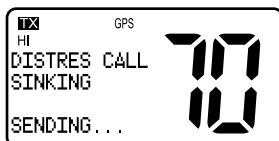

After the Distress transmission, the radio is automatically set to channel 16 at high power to listen for and respond to voice replies from SAR authorities or other vessels that may have received your Distress Call.

The Distress Call is resent randomly every 3.5 – 4.5 minutes until an acknowledgement is received or the call is manually cancelled.

To cancel the automatic Distress resend: press **CLEAR**.

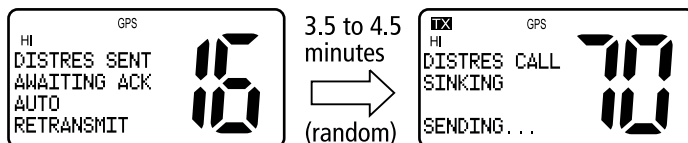

Cancelling a Distress Call Made in Error

If you should send a Distress Call in error, you should make an announcement as soon as possible that the distress situation does not exist.

1. Immediately power off the radio to cancel the Distress Call.
2. Power the radio back on and set to channel 16.
3. Make a broadcast to all stations giving your ship's name, call sign and MMSI number and cancel the false distress alert.

Sample Announcement to Cancel a Distress Call Made in Error:

“All Stations, All Stations, All Stations. This is NAME, CALL SIGN, MMSI NUMBER, POSITION. Cancel my distress alert of DATE, TIME, NAME, CALL SIGN.”

Receiving a Distress Call

DISTRESS

The Ray54E receives distress messages sent by another vessel and/or acknowledgments (ACK) sent by a coast station to another vessel in distress. The radio also receives distress relays. In such cases you should maintain radio silence and a listening watch on channel 16 and standby to lend assistance if requested.

When a Distress Call is received, the Ray54E automatically tunes to channel 16 and sounds the Distress Alarm Tone. (If you have disabled automatic channel changing, as described on *page 82*, you are first prompted whether to accept the call.)

► To silence the alarm:

Press any key. Automatic alarm cancellation takes place after 2 minutes.

Two alternating screens appear in the display. When position data and time is included within the signal, it is displayed on the first screen in the text area of the LCD. If invalid GPS or Time data is received, the lat/lon position shows ‘9’ in all digits and the time shows all ‘8’s. The second screen shows the nature of the distress and the time it was sent. The 2 alternating pages of data are recorded in the Distress Call Log.

Maintain radio silence and a listening watch on channel 16 and standby to lend assistance if requested.

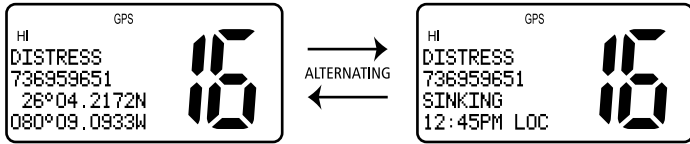

Note: The *AUTO CH CHG* option determines whether you want your radio automatically switched to channel 16 to receive the call or instead to be prompted to manually receive or decline the channel change. See page 82.

Receiving a Distress ACK Sent from a Coast Station

DISTRESS When a Distress ACK is received from a Coast Station (Coast Guard or Search and Rescue) the Distress alarm sounds. The LCD displays the Name/MMSI ID of the vessel in distress. Maintain radio silence and a listening watch on channel 16 and standby to lend assistance if requested.

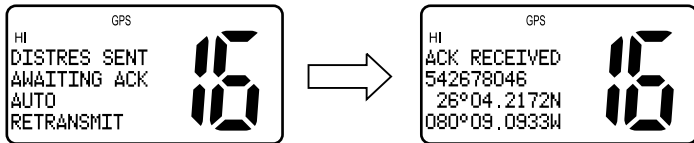

Receiving a Distress Relay Sent by Another Station

DISTRESS When a Distress Relay is received from another station, an alarm sounds and the LCD displays two alternating screens. The first page displays the Name/MMSI ID of the station sending the message. The second page displays the Name/MMSI ID of the vessel in distress and its lat/lon position. Your radio does not re-send a distress relay message.

Maintain radio silence and a listening watch on channel 16 and standby to lend assistance if requested.

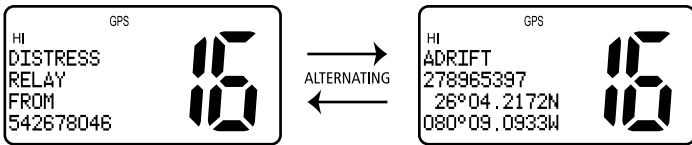

Station sending message

Station in distress

5.6 Position Request

With this option you can request GPS position information from any station capable of responding to this type of call and for which an MMSI number is known. You can specify the target station either by selecting it from your MMSI phonebook or by manually entering its MMSI number.

Specifying the Target Vessel

POS REQUEST

1. Press and release the **CALL/MENU** key to enter the DSC menu. The arrow is pointing to **INDIVIDUAL**.

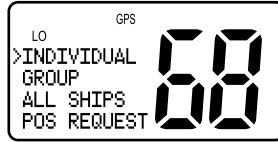

2. Rotate the **CH** knob to select **POS REQUEST**.

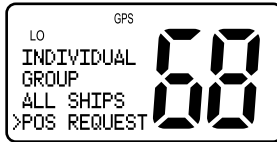
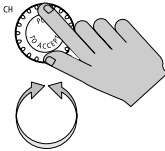

3. Push in the **CH** knob to select **POS REQUEST**. The Position Request menu appears.

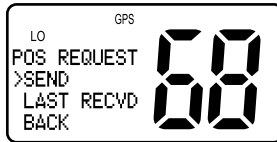

4. Push the **CH** knob again to select **SEND**. Choose the target vessel from the phonebook.



- 5. Rotate the **CH** knob until the arrow points to the desired name.



If using MANUAL MMSI ID entry:

Enter the MMSI number using the **CH** knob. Rotate the **CH** knob to select each character and then push in the **CH** knob to accept. A full description of manual character entry can be found in *Adding an Entry on page 59*.

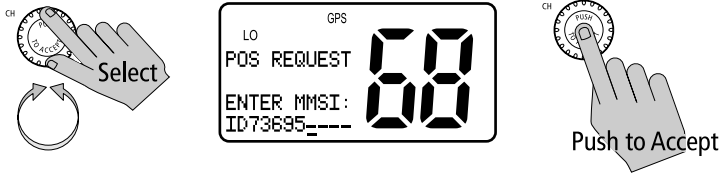

- 6. Push in the **CH** knob to select the desired name/MMSI ID.



- 7. Press the **CH** knob again to send the Position Request Call.

The call is transmitted on channel 70, and then the radio tunes to the original channel and waits for acknowledgement. During this period you are still able to receive calls.

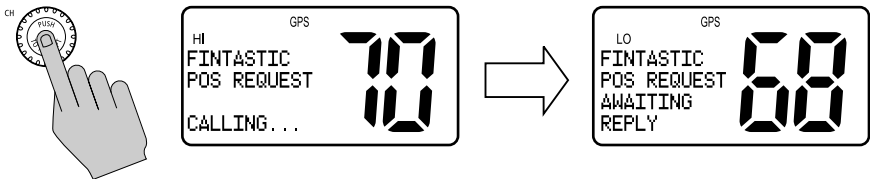

- Notes:**
- (1) Pressing **PTT** at any time before reply is received cancels the Position Request. In this case, you must resubmit the request.
 - (2) To conform with regulations of the Basel Agreement for radiotelephone service on inland waterways, DSC functions are disabled when **ATIS** is active. See *ATIS Function on page 79*.

When the Position Request is accepted by the receiving station:

When the position request is received, the Ray54E shows that the call has been accepted by the requested station. The radio sounds a Call Alert tone. Press any key to mute the alert tone. It shuts off automatically after two minutes.

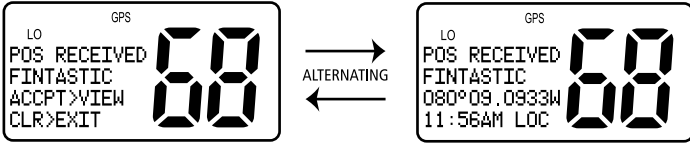

Push in the **CH** knob to view the data. The radio automatically jumps to the the LAST RECVD log, where the data is displayed. Exit the log by pressing **CLEAR**.

Press **CLEAR** to exit to normal radio operation. You can retrieve the position information later using the LAST RECVD option.

When no reply is received within 3 minutes:

The radio prompts you to resend the call. After a total of 5 minutes of inactivity, the Position Request Call is cancelled and the message NO REPLY POS REQUEST ABORT is displayed. The message disappears after pressing **PTT**.

Retrieving the Last Received Position Data

- POS REQUEST** 1. From the Position Request screen, rotate **CH** to select LAST RECVD.

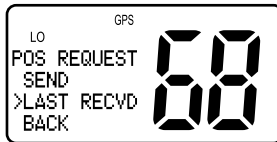
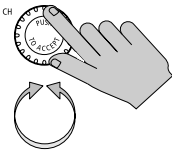

2. Push the **CH** knob to select. The last received position request data is displayed.

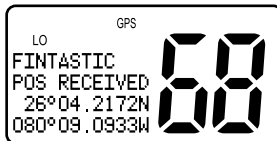

Note: Only the last position is saved. The next received position will overwrite the existing position data.

Press the **CLEAR** key to exit the LAST RECVD window.

Receiving a Position Request From Another Station

POS REQUEST If you receive a position request from another station, how the Ray54E responds depends on the option you have set in the *Position Reply* menu item (see page 81). OFF will not send position data under any circumstances. AUTOMATIC sends out your vessel’s position data as soon as it is requested. MANUAL sends out the data only after you respond to the request.

When a Manual Position Reply is received, the requesting station’s MMSI number or station name (if entered in the Phonebook) is displayed.

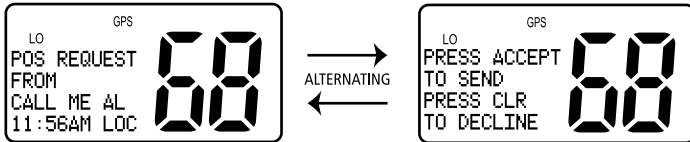

Push in the **CH** knob to view and accept the request to send your position data. Decline the request by pressing **CLEAR**.

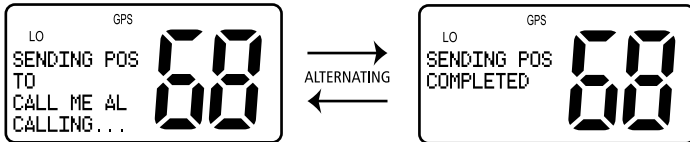

5.7 Call Log

The Call Log is a list of the last 20 DSC received INDIVIDUAL, GROUP and ALL SHIPS call types by number and time of call. This does not include Distress Calls, which are maintained in their own log.

If the calling vessel or station is listed in your DSC Phonebook, the vessel or station name appears in the display as it is listed. If the caller is not listed in your directory, the caller’s MMSI ID number appears in the display. Usually, the radio is set to a channel selected by the caller if a channel change request is accepted.



When a DSC Call is received, the envelope icon appears on the LCD. The envelope icon disappears when the log is opened.

1. **Press and release** the **CALL/MENU** key to enter the DSC menu. The arrow is pointing to INDIVIDUAL.

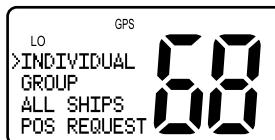

2. Rotate the **CH** knob until the arrow points to CALL LOG.

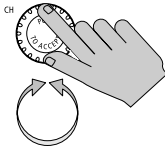

3. Push in the **CH** knob to select the Call Log. Entry 01 appears first with call type and time of the last call. This is the most recent call.



4. Using the **CH** knob, scroll down the list of up to 20 entries.

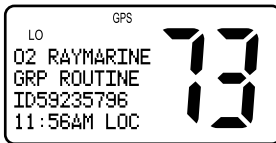
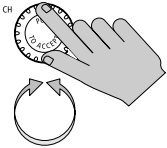

...

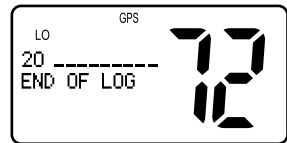

If the caller had requested a change to an unsupported working channel, UC appears in the Channel Number field, indicating the radio was Unable to Comply with the channel change request.

Making a Call from a Call Log Entry

You can make a routine Individual Call to any caller listed in the log.



1. Rotate the **CH** knob until the log entry you wish to call appears.
2. For received Individual or All Ships Call, push the **CH** knob. The Individual Call screen appears addressed to the caller.

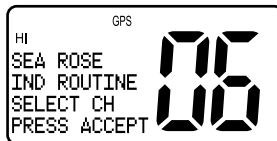
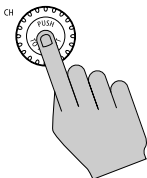

3. Follow the same directions you would for initiating an Individual Call using the Phonebook, as outlined on *page 34*.
4. To make a Group Call using the Call Log, push the **CH** knob to bring up the Group Call menu and make the call as described in *Transmitting a Group Call on page 5-38*.

Saving an MMSI ID Number from a Call Log Entry

Any undefined MMSI number that is listed on an entry in the Call Log can be saved into the Phonebook.



1. Rotate the **CH** knob to select the desired Call Log entry.



2. **Press and hold** the **SCAN/SAVE** key.

The MMSI number is entered in the appropriate field of the Phonebook.



3. Use the **CH** knob to enter the **NAME** that you wish to have associated with this MMSI ID number. Rotate the **CH** knob to select each character and then push in the knob to accept it.

Note: *In this operation, only the Name field can be edited. You can only edit the MMSI ID from the Phonebook.*

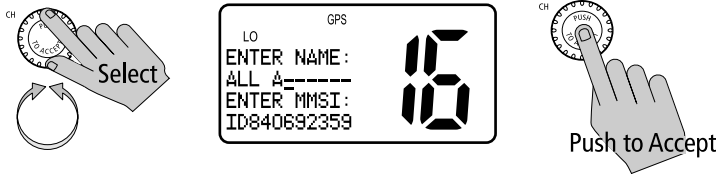

4. When the **NAME** entry is complete, push in the **CH** knob to accept it.

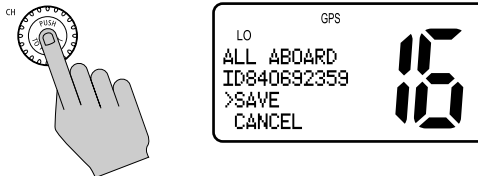

5.8 DSC Distress Log

The Distress Log is a list of all received DSC Distress Calls by number and time of call. The Log maintains up to 10 calls.

When a DSC Distress Call is received, the envelope icon blinks on the LCD. The envelope icon disappears when the log is opened.



► To view the Distress Call Log:

1. **Press and release** the **CALL/MENU** key to enter the DSC menu. The arrow is pointing to INDIVIDUAL.

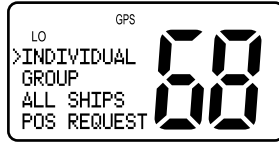

2. Rotate the **CH** knob until the arrow points to DISTRES LOG.

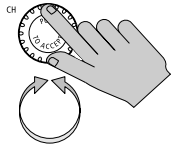

3. Push the **CH** knob to select the Distress Log. Entry 01 (the most recent call) appears first with call type and position data. The screen then flashes to display the nature of the distress and time of the call.

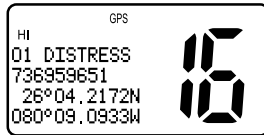
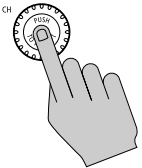

ALTERNATING

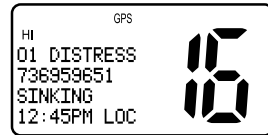

4. Rotate the **CH** knob to scroll down the list of up to 10 entries.

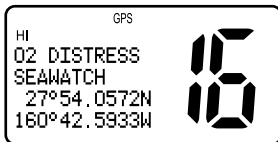
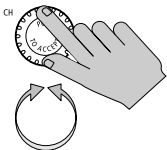

...

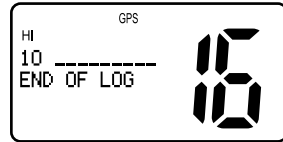

Chapter 6: Menu Settings

6.1 Menu Function



The radio's setup functions are accessed through the Menu mode. Menu mode selections are as follows.

Item	Description
PHONEBOOK	A list of frequently-called DSC stations that you can select for making an Individual Call. Up to 20 Phonebook entries can be stored.
BACKLIGHTING	Selects the backlight levels for the LCD, main unit keypad and microphone keypad.
CONTRAST	Selects the LCD contrast setting.
GPS/TIME	Used to manually set latitude/longitude position and UTC time for a DSC distress message. Also selects how the data is displayed on the LCD.
RADIO SETUP	Selects four separate radio settings: a) BAND – Frequency Group (US, International, Canadian) b) CH NAME – Descriptive name for each channel (up to 12 characters) c) RING VOLUME – Alert tone volume (LOUD or SOFT) d) KEY BEEP – Key beep volume (LOUD, SOFT or OFF)
DSC SETUP	Selects the following DSC settings: a) MY MMSI ID – Used for one-time entry of the MMSI number required for DSC functions. If already programmed, displays the saved MMSI ID number. b) GROUP SETUP – Stores up to 3 Group MMSI IDs and associated Names c) MY ATIS ID – Used for one-time entry of the ATIS number. If already programmed, displays the saved ATIS ID. d) ATIS FUNC – Turns ATIS function ON or OFF e) POS REPLY – Selects how Position Request data is transmitted f) AUTO CH CHG – Selects whether your radio automatically switches to the requested working channel when DSC Calls are received.
RESET	Enables a return to factory default settings.

► To make Menu selections:

1. **Press and hold** the **CALL/MENU** key to enter Menu mode. The list of available functions appear on the dot matrix display.

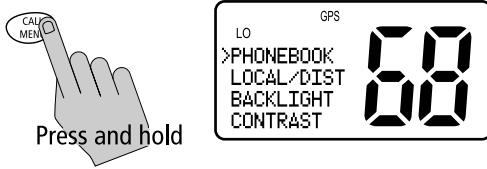

2. Rotate the **CH** knob to scroll down the list until the arrow points to the desired function. Push the **CH** knob to accept.



To exit the Menu mode or sub-mode, press the **16/PLUS** or **CLEAR** keys, or else select the EXIT option from the menu.

Using the Microphone Keys to Make Selections

The examples in this chapter describe how to make menu and character selections using the **CH** knob on the main unit. However, you can also press the microphone **UP/ DOWN** keys to make selections and then press the microphone **HI/LO** key to accept.

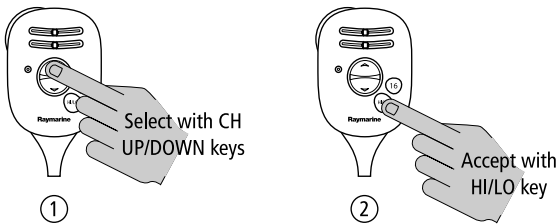

6.2 DSC Phonebook

PHONEBOOK The Phonebook stores up to 20 preprogrammed MMSI numbers that you can select for making an Individual Call. The numbers are stored by name and contain the station’s MMSI number. You can add, edit and delete entries from the Phonebook, much as you would on a cellular telephone. Rotate the **CH** knob to make an item appear on the dot matrix display and then press in the **CH** knob to select that item.

Note: *The following examples demonstrate making calls to other ship stations. You may also make DSC Calls to shore stations. Shore station MMSI numbers start with “00”.*

Adding an Entry

PHONEBOOK 1. Press and hold the **CALL/MENU** knob. The Menu screen appears on the dot matrix display.

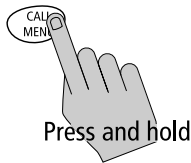

2. Press the **CH** knob to select Phonebook. The Phonebook screen appears.

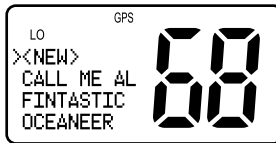

3. Press and release the **CH** knob to select <NEW ENTRY>.

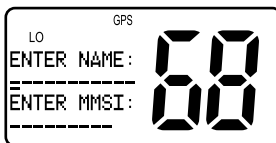

4. Using the **CH** knob, fill in the NAME field one character at a time. The first character space to be modified is highlighted with a flashing underline. All alpha and numeric characters are available, as well as 11 symbols, a blank (space) and a left arrow (<), which represents a backspace. A total of 11 character spaces are available.

- i. Rotate the **CH** knob to scroll through the selections.
Note: *The last selection in each field is a left arrow (<), which represents a BACKSPACE. Accepting the arrow returns the current character to its default value and moves you back to the previous position.*
- ii. When the desired character appears, push in the **CH** knob to accept it. The next character to be filled in sequence is underlined ().
- iii. Continue this process until all characters have been selected.

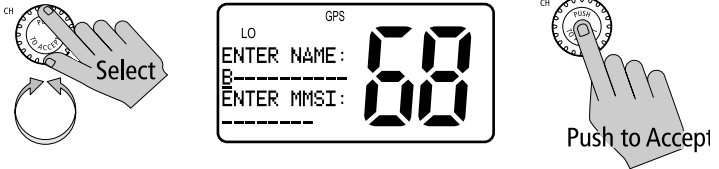

Note: *Pressing and holding CH indicates you have completed editing the current line and forwards you to the first position of the next line. This eliminates the need to accept each character individually.*

You can also press the microphone UP/ DOWN keys to select each character and then press the microphone HI/LO key to accept.

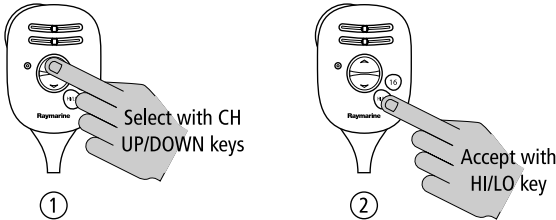

- 5. Continue this process until all NAME characters are selected. **Press and hold** the **CH** knob to accept the name and move on to the MMSI ID.

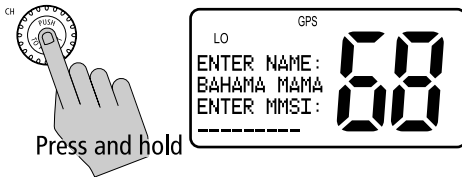

- 6. Use same procedure to enter the MMSI characters.

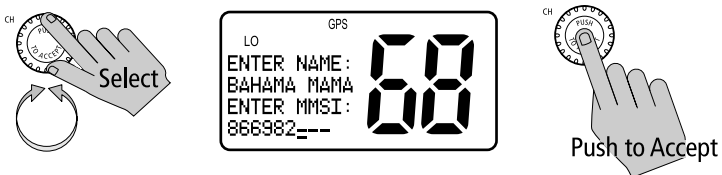

- When all characters have been selected, press the **CH** knob to **SAVE**. The new entry appears in the Phonebook.

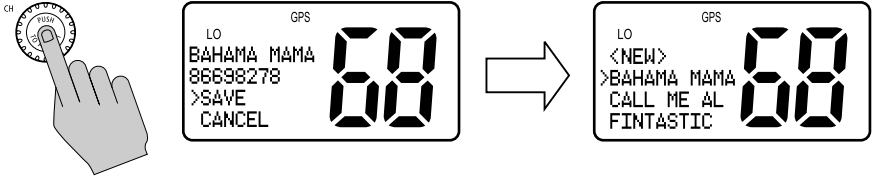

Editing an Existing Entry

PHONEBOOK

- From the Phonebook, rotate the **CH** knob until the arrow on the dot matrix display points to the entry you wish to edit.



- Push in the **CH** knob to select the name.



- Push the **CH** knob again to select **EDIT**.

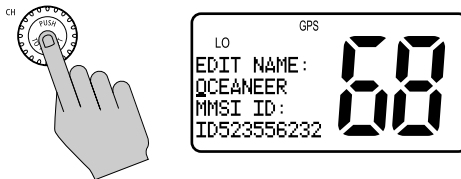

- Make your changes to the **NAME** and **MMSI ID**, using the **CH** knob.

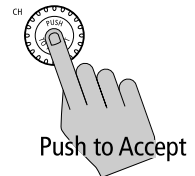
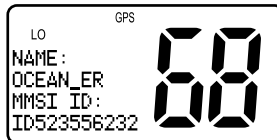
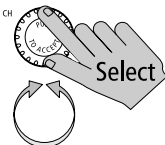

- When finished, push the **CH** knob to SAVE. The revised name appears in the list.

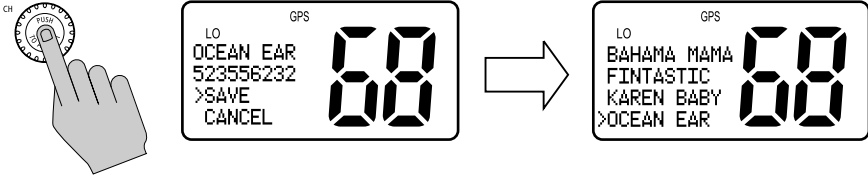

Deleting an Existing Entry

PHONEBOOK

- From the Phonebook, rotate the **CH** knob until the arrow on the dot matrix display points to the entry you wish to delete.



- Push the **CH** knob to select the name.



- Rotate the **CH** knob until the arrow is pointing to DELETE.



- Press and hold** the **CH** knob. The entry is removed.

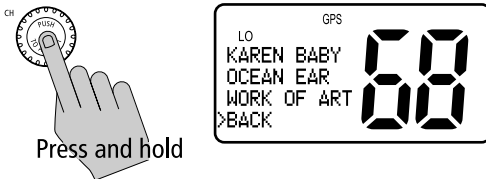

6.3 Backlight Adjustment

BACKLIGHT This setting adjusts the backlight brightness for the LCD, microphone keypad and main unit keypad. Choose from 8 brightness settings or OFF.

► To adjust the backlight setting:

1. Rotate the **CH** knob until the arrow points to BACKLIGHT.
2. Push the **CH** knob to accept. The Backlight screen appears.
3. Rotate the **CH** knob to select the desired backlight level. The number of blocks illuminated on line 3 of the dot matrix display indicate the level, one through eight. For HI all eight are illuminated; for OFF none are illuminated. Push the **CH** knob to accept.



The Distress key backlighting is never turned OFF.

6.4 Contrast Adjustment

CONTRAST This setting adjusts the levels of LCD contrast. Choose from 8 settings.

► To adjust the contrast setting:

1. Rotate the **CH** knob to scroll until the arrow points to CONTRAST.
2. Push the **CH** knob to accept. The Contrast screen appears.
3. Rotate the **CH** knob to select the desired contrast level. The number of blocks illuminated on line 3 of the dot matrix display indicate the level, one through eight. A larger number of blocks indicate a darker LCD. For HI all eight blocks are illuminated; for LO none are illuminated.
4. Push the **CH** knob to accept your selection.

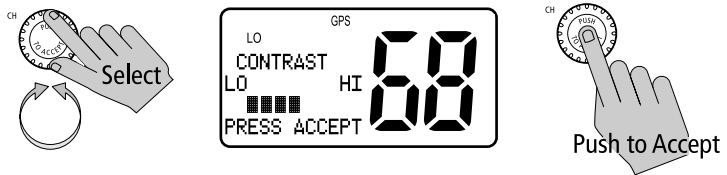

6.5 GPS/Time Setup

By default, the Ray54E auto-detects NMEA strings and decodes appropriate latitude/longitude position and time. If the GPS navigation receiver is not connected or is not functional, a manual latitude/longitude position and UTC time can be entered and used in the DSC distress transmitted message.

When GPS Information Not Available

If no GPS data is available, the NO GPS icon appears, POS DATA REQ is displayed on the dot matrix display, followed by NO POS DATA. An alarm sounds for 5 seconds or until you acknowledge by pressing any key.

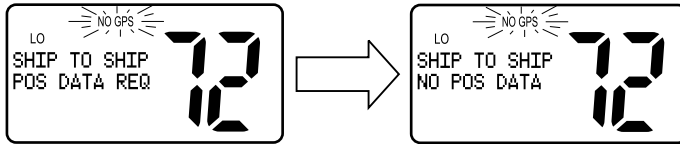

The position (lat/lon) fields are set to all 9's and time field is set to all 8's. The alert repeats every four hours as long as no position information has been entered manually. If position data is entered manually but has not been updated during the previous 23.5 hours, all the position fields are set to 9's and the display reverts to NO POS DATA.

Note: *The Manual Lat/Lon function is valid only when your radio is not connected to a GPS receiver.*

GPS/TIME

► To manually set the GPS position and time settings:

1. Rotate the **CH** knob to scroll down the list until the arrow points to GPS/TIME.

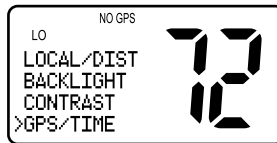
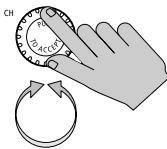

2. Push in the **CH** knob. The arrow is pointing to MANUAL POS.

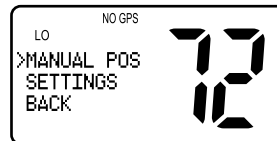

3. Push **CH** again to accept. The Manual Position screen appears.

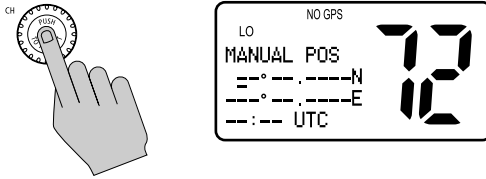

4. Using the **CH** knob, fill in the Lat/Lon information, one character at a time. The first character space is highlighted with a flashing underline.

i. Rotate the **CH** knob to scroll through the selections.

Note: The last selection in each field is a left arrow (<), which represents a BACKSPACE. Accepting the arrow returns the current character to its default value and moves you back to the previous position.

ii. When the desired character appears, push in the **CH** knob to accept it. The next character to be filled in sequence is underlined (_).

iii. Continue this process until all latitude data been selected.

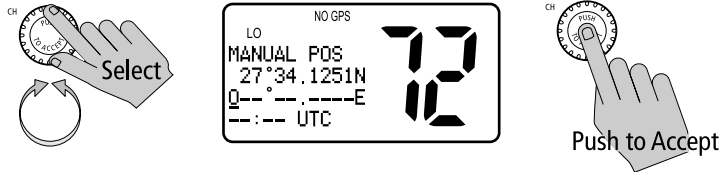

You can also press the microphone UP/ DOWN keys to select each character and then press the microphone **HI/LO** key to accept.

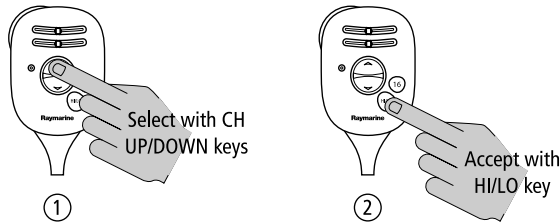

5. Use the same process to complete longitude information.

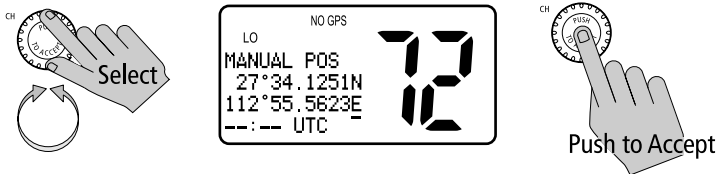

6. Push in the **CH** knob to accept and move onto UTC time. Select the time characters in the same manner.

Note: You must enter the *TIME* parameter in UTC time and not in local time.

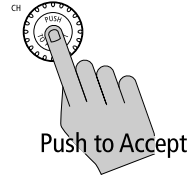
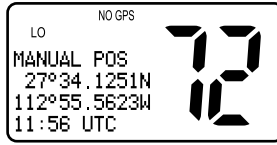
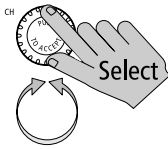

When time data is entered manually, the NO GPS indicator remains illuminated and the UTC designator appears following the time.

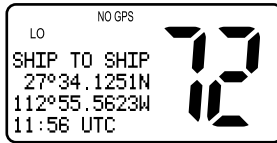

Note: When the final selection is made the radio returns to the previous Menu Selection. To exit this sub-mode, select **BACK** or else press the **16/PLUS** or **CLEAR** keys.

6.6 Settings

You can also set how some time and position information is displayed on the screen:

- whether Lat/Lon data is displayed
- whether the Time is displayed
- whether a Time Zone Offset is used
- how the Time data is formatted
- whether COG/SOG data is displayed



➤ To adjust these Settings:

1. **Press and hold** the **CALL/MENU** key to enter Menu mode.

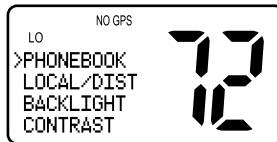
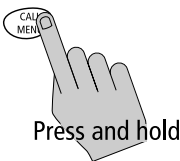

- 2. Rotate the **CH** knob until the arrow points to GPS/TIME.



- 3. Push the **CH** knob to accept. The GPS/Time screen appears.

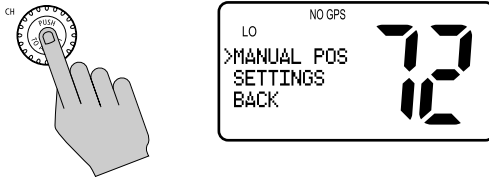

- 4. Rotate the **CH** knob and scroll down the list to SETTINGS.

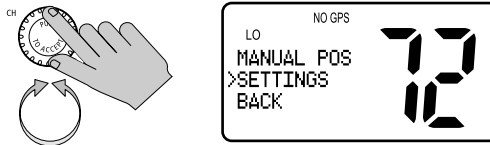

- 5. Push the **CH** knob to accept.

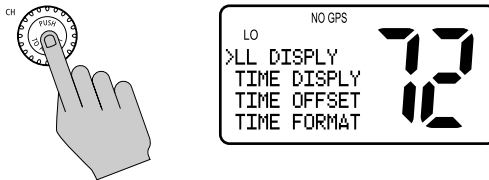

Make your selection from the options on the list, which are described as follows.

Latitude/Longitude Display

The LL/DISPLY setting indicates whether Latitude and Longitude position data are displayed on the screen in normal mode.

Time Display

The TIME DISPLY setting indicates whether time information is displayed on the screen in normal mode.

When manual time is used, it is always displayed as UTC time, even if you have entered an offset. The NO GPS icon remains until valid GPS information is available.

Note: *If TIME DISPLY is set ON, COG/SOG is automatically set to OFF. Because they occupy the same line on the LCD, only one of these two settings can be displayed at a time.*

Time Offset

The TIME OFFSET setting indicates the amount of time to add or subtract from UTC time to equal your local time.

Note: *The Time Offset setting is valid only when GPS data is available. When manual time is used, it is always displayed as UTC time, even though you have entered an offset.*

Time Format

The TIME FORMAT setting indicates whether the time is displayed in 12 hour or 24 hour format.

COG/SOG Display

This setting determines whether Course Over Ground and Speed Over Ground (COG/SOG) data is displayed on the bottom line of the dot matrix display instead of the time of day. The letter “T” is always appended to the COG, indicating that this is a True (and not Magnetic) heading.

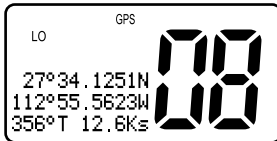

Note: *If COG/SOG is set ON, TIME DISPLY is automatically set to OFF. Because they occupy the same line on the LCD, only one of these two settings can be displayed at a time.*

6.7 Radio Setup

The Radio Setup menu item is used to determine four separate settings:

- Frequency Band
- Channel Name
- Ring Volume
- Key Beep

RADIO SETUP

➤ To adjust these settings:

1. Press and hold the **CALL/MENU** key to enter Menu mode.



2. Rotate the **CH** knob to scroll down the list until the arrow points to RADIO SETUP.

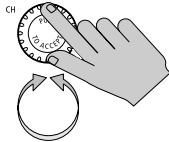

3. Push the **CH** knob to accept. The Radio Setup screen appears.

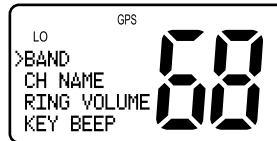

Make your selection from the options on the list, described as follows.

Band

The Ray54E can transmit and receive all USA, International and Canadian frequencies, if available. This setting determines which channel set is being used. The appropriate indicator is illuminated in the LCD: U for US, I for International, or C for Canadian channel sets.

Channel (CH) Name

By default, the Ray54E lists a descriptive name of up to 12 characters in the top line of the dot matrix display for each channel. This option modifies the name for the currently-selected channel from its default.

Display Name

Use this option to toggle the Channel Name ON or OFF. If off, the top line of the dot matrix display is blank for that channel.

CH Info

Using this feature you can delete or change the Channel Names from the default.

1. From the CH NAME menu item, rotate the **CH** knob until the arrow on the dot matrix display points to CH INFO.
2. Push in the **CH** knob to select. The currently assigned name appears.
3. Push the **CH** knob to display your options:
EDIT changes the channel name displayed.
CLEAR completely removes the channel name. The top line of the dot matrix display is blank for that channel.
4. Push **CH** again to select EDIT or CLEAR.
5. If you select EDIT, use the **CH** knob to modify the NAME field using the same technique described in *Adding an Entry on page 59*.

Deleting a Channel Name Entry

Use this feature to completely remove a Channel Name from the list. If the name is deleted, the top line of the dot matrix display is blank for that channel.

Note: *The CH NAME is not returned to the factory default value following a reset (page 84).*

Ring Volume

This setting is used to set the volume of the ring that is sounded when an incoming call is received. Select HIGH or LOW.

Note: *The ring volume setting is overridden if a DSC Urgency or Distress Call is received. These alarms must meet volume levels required by regulations.*

Key Beep

This setting is used to set the volume of the beep that sounds when a key is pressed. Select HIGH, LOW or OFF.

6.8 DSC Setup

The DSC Setup menu item is used to determine these six functions:

- the radio’s MMSI ID number
- the radio’s Group MMSI ID number
- the radio’s ATIS ID number
- whether the ATIS function is turned on or off
- how your radio responds to a Position Reply request
- whether your radio automatically changes channels for incoming Distress and All Ships Urgency Calls

DSC SETUP ➤ To adjust the DSC Settings:

1. **Press and hold** the **CALL/MENU** key to enter Menu mode.

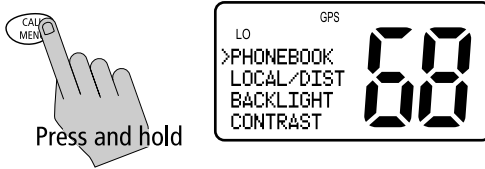

2. Rotate the **CH** knob to scroll down the list until the arrow points to **DSC SETUP**.



3. Push the **CH** knob to accept. The DSC Setup screen appears.



Make your selection from the following options:

- MY MMSI ID
- GROUP SETUP
- MY ATIS ID
- ATIS FUNC
- POS RPLY
- AUTO CH CHG

My MMSI ID

This operation stores the MMSI number required for DSC communications, including Distress Calls. If regulations in your area do not permit you to program the MMSI number yourself, your Raymarine dealer/distributor can program the number for you.

If you try to access a DSC function before entering the MMSI number, an error message appears and you are prompted to enter the MMSI ID.

This is a one time operation.

After the MMSI number has been programmed:

- you will not be able to change it
- only your dealer/distributor can change it
- after entering your MMSI ID, accessing this menu item will merely display the programmed number

DSC SETUP

► To enter or view the MMSI ID number:

1. From the DSC SETUP menu item described on *page 71*, rotate the **CH** knob until the arrow points to MY MMSI ID.

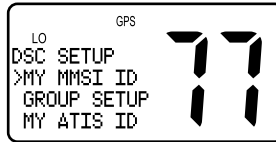
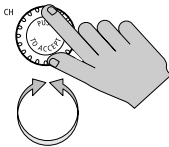

2. Push the **CH** knob to accept. If an existing MMSI ID is stored, the value appears. If the MMSI ID is blank, dashes appear, indicating that one has yet to be entered.

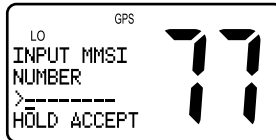

3. To enter the MMSI ID number, rotate the **CH** knob to select the digits using the same technique described in *Adding an Entry on page 59*.

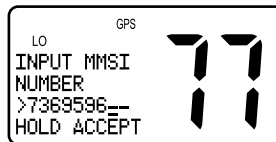
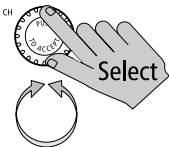

Push to Accept

- When all digits are selected, **press and hold** the **CH** knob to accept.

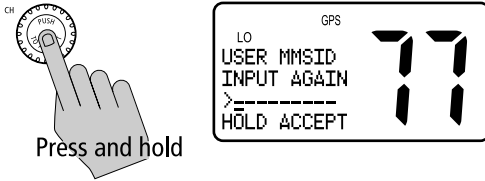

- Re-enter** all nine MMSI digits.

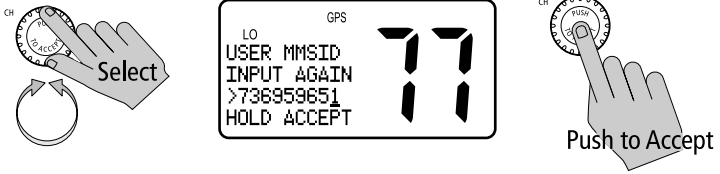

- When complete, **press and hold** the **CH** knob to accept.

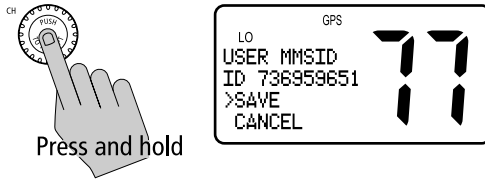

- Press the **CH** knob one last time to save the MMSI ID number.

If the second entry does not match the first entry, the radio exits MY MMSI ID and returns to the previous menu.

Note:

- You cannot begin the MMSI ID number with “0” (single zero), as this prefix indicates a GROUP ID.
- You cannot begin the MMSI ID number with “00” (double zero), as this prefix indicates a COAST STATION.

The Ray54E is designed to be used as a recreational Ship Station only.

Group MMSI Setup

This operation sets up the MMSI number that is used for DSC Group Calls between radios that share a common Group MMSI number. You can program up to three Group MMSI ID numbers and associated Group names, which can be up to 11 characters long. Group MMSI ID numbers always begin with a zero (0). You only enter the last 8 digits of the Group ID number; the initial “0” is automatically entered for you.

Adding a New Group

DSC SETUP

1. From the DSC SETUP menu item described on *page 71*, rotate the **CH** knob until the arrow points to GROUP SETUP.

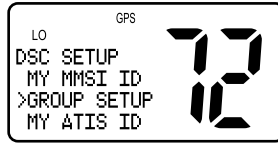
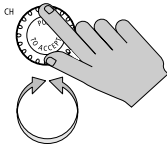

2. Press the **CH** knob to accept. If an existing Group name and MMSI ID number are already stored, those values appear. If blank, <EMPTY 1>, <EMPTY 2>, and <EMPTY 3> are shown to indicate that the Group IDs have not yet been programmed into the radio.

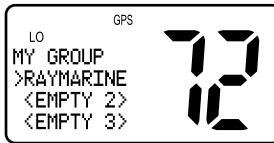

3. Rotate the **CH** knob until the arrow points to the first available empty group location.

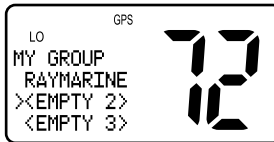
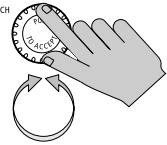

4. Press the **CH** knob to accept. The first field for you to enter data is the GROUP NAME.

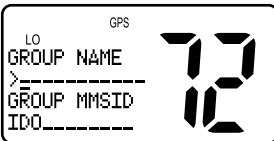

5. Use the **CH** knob to modify the GROUP NAME field using the same technique described in *Adding an Entry* on *page 59*.

- 6. Continue this process until all GROUP NAME characters have been entered. **Press and hold** the **CH** knob to accept the name and move on to the GROUP ID.

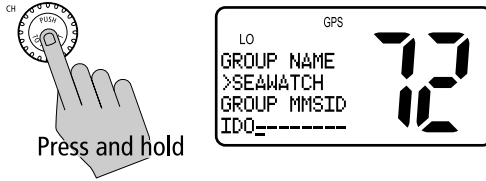

- 7. Use the same procedure to enter the GROUP ID numbers.

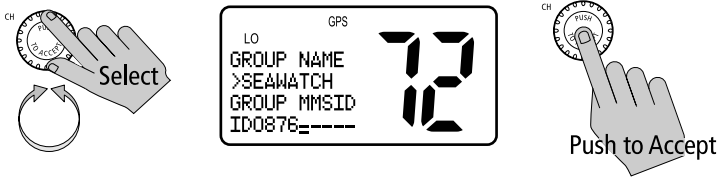

- 8. **Press and hold** the **CH** knob to accept.

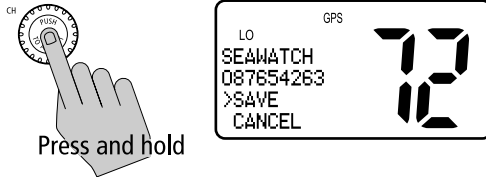

- 9. **Press** the **CH** knob one more time to save. The new entry appears in the list.



Editing an Existing Entry

DSC SETUP

1. From the DSC SETUP menu item described on *page 71*, rotate the **CH** knob until the arrow points to GROUP SETUP.

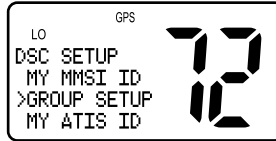
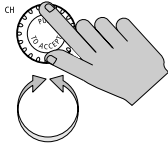

2. Press the **CH** knob to accept.

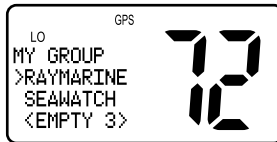
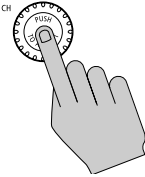

3. Rotate the **CH** knob until the arrow points to the group location you wish to edit.

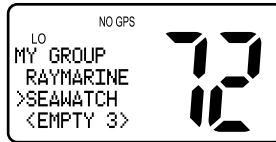
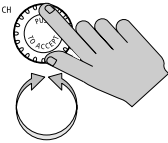

4. Press the **CH** knob to select that Group.

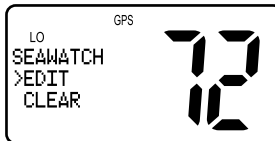

5. Press the **CH** knob again to select EDIT.

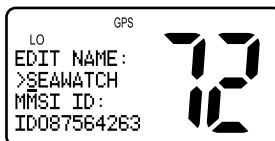

- 6. Make your changes, using the **CH** knob using the same technique described in *Adding an Entry* on page 59.
- 7. **Press and hold** the **CH** knob to accept your changes.

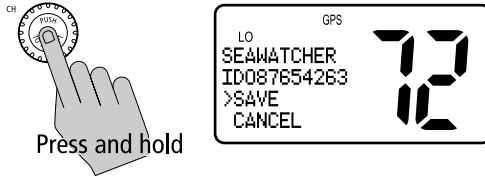

- 8. **Press** the **CH** knob to save. The revised entry appears in the list.



My ATIS ID

If you purchased your Ray54E to include use on the inland waterways of the contracting governments of the Basel Agreement, your Ray54E has been programmed by your dealer to include Automatic Transmitter Identification System (ATIS) functionality. The Basel Agreement includes Germany, Austria, Belgium, Bulgaria, Croatia, France, Hungary, Luxembourg, Moldova, the Netherlands, Poland, Romania, Russian Federation, the Slovak Republic, Switzerland, the Czech Republic, Ukraine and the Federal Republic of Yugoslavia.

ATIS includes data at the end of radio transmission that identifies your station. Your ATIS ID number is derived from your vessel's call sign. Your authorized Raymarine dealer can assist you in decoding the number. You can then program the ATIS number into your Ray54E using the operation described in this section. If regulations in your area do not permit you to program the ATIS number yourself, you can have your dealer program the number for you.

Note: *The ATIS ID number is a ten digit number, beginning with a "9". The MY ATIS set up process has you input only the last 9 digits. The leading "9" is automatically input for you.*

This is a one time operation. After the ATIS number has been programmed:

- you will not be able to change it, only your dealer/distributor can do this
- accessing this menu item will display the programmed ATIS number

► To enter or view the ATIS ID number:

DSC SETUP

1. From the DSC SETUP menu item described on *page 71*, rotate the **CH** knob until the arrow points to MY ATIS ID.

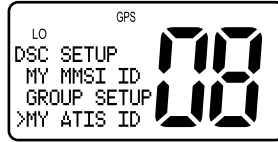
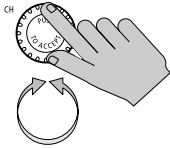

2. Press the **CH** knob to accept. If an existing ATIS ID is stored, the values appear. If the ATIS ID is blank, dashes appear, except for the initial '9'.

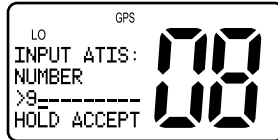

3. Rotate the **CH** knob or use the microphone UP/ DOWN keys to scroll through the digits for entry into the ATIS ID field. The final available character is an arrow, which serves as a backspace. The initial character position is indicated by a blinking underline.

When the desired character appears, press and release the **CH** knob or the microphone **HI/LO** key to accept it. The next position now has the blinking underline, indicating it is ready to be selected.

Continue in this manner until all nine digits have been selected.

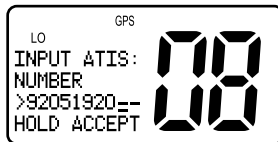
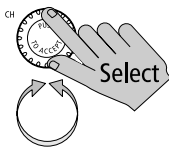

You can also press the microphone UP/ DOWN keys to select each character and then press the microphone **HI/LO** key to accept.

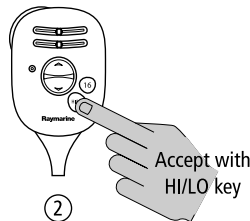
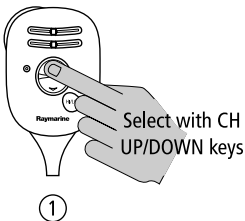

4. When complete, **press and hold** the **CH** knob to accept.

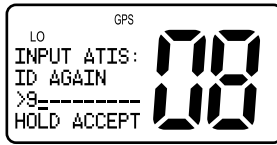

5. **Re-enter** all nine ATIS digits.

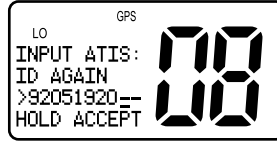
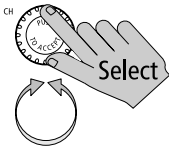

6. When complete, **press and hold** the **CH** knob to accept.

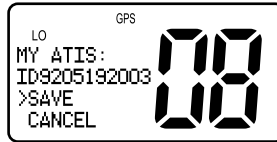
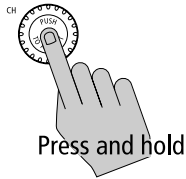

7. Press the **CH** knob one last time to save the ATIS ID number.

If the second entry does not match the first entry, the radio exits MY ATIS ID and returns to the previous menu for you to retry.

ATIS Function

This operation enables or disables the Automatic Transmitter Identification System (ATIS) feature in the radio. This feature accommodates users who travel outside the inland waterways and wish to disable the ATIS function at that time.

Note: *If you purchased your Ray54E to include use on the inland waterways of the contracting governments of the “Regional Arrangement Concerning the Radiotelephone Service on Inland Waterways” – also known as the Basel Agreement – your Ray54E has been programmed by your dealer to include ATIS. If ATIS is enabled, certain programming steps have been implemented to protect the integrity of this agreement, including the blocking of DSC functions when ATIS is active.*

When ATIS is enabled, the following occurs:

- DSC functions are disabled.
- Dual Watch, Tri Watch and all Scan functions are disabled.
- The following International Channels are limited to 1 watt output power: 6, 8, 10, 11, 12, 13, 14, 15, 17, 71, 72, 74, 75, 76, 77 (and 31, if enabled).

➤ To enable/disable ATIS:

DSC SETUP

1. From the DSC SETUP menu item described on *page 71*, rotate the **CH** knob until the arrow points to ATIS FUNC.

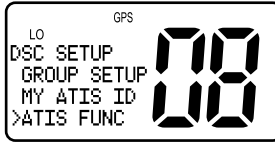
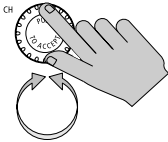

2. Press the **CH** knob to accept.

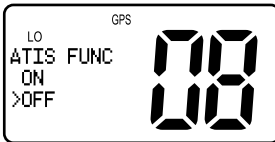

3. Rotate the **CH** knob to select between switching the ATIS function ON or OFF.

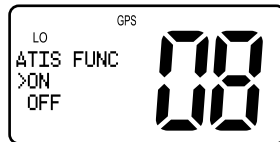
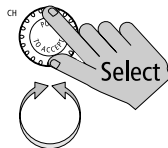

4. Press the **CH** knob to accept. If enabled in the previous step, the ATIS icon appears.

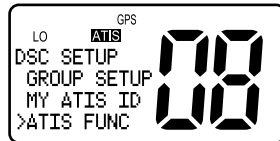

Position Reply

This option enables you to determine how your radio responds to a request for your GPS position information (lat/lon) from another station.

DSC SETUP

➤ To enable/disable Position Reply:

1. From the DSC SETUP menu item described on *page 71*, rotate the **CH** knob until the arrow points to POS REPLY.

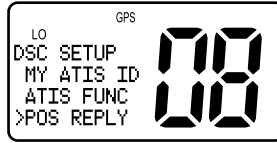
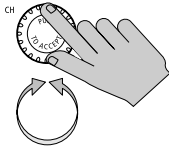

2. Press the **CH** knob to accept.

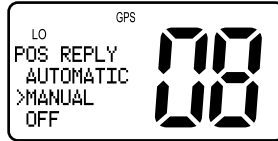

3. Rotate the **CH** knob to select the desired setting and push to accept.

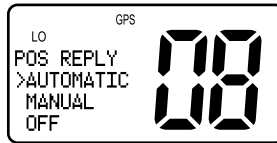
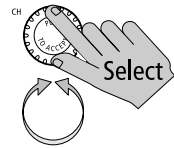

AUTOMATIC sends out your vessel's position data as soon as it is requested. MANUAL sends out the data only after you respond to the request. OFF will not send position data under any circumstances, nor notify you that the request has been made.

The default setting is MANUAL, which is described in *Receiving a Position Request From Another Station* on *page 53*.

Note: *The Position Reply function is only available when a working GPS is connected to the radio.*

Automatic Channel Changing for Incoming Calls

For incoming Distress and All Ships Urgency Calls, this option determines whether your radio automatically switches to Priority Channel 16 to receive the call or prompts you to manually accept or decline the channel change.

The default setting is to ENABLE the auto channel change.

This feature is useful for preventing your radio from automatically switching channels while you are maintaining a continuous watch on a certain channel (for example, in a VTS controlled area) or working with other vessels (for example, for towage).

Note: *This feature can disable automatic channel switching for incoming DSC Distress and All Ships Urgency Calls. If enabled, you are responsible for determining whether manually declining the call is appropriate.*

By regulation, this feature cannot disable the automatic switching of Individual Distress and Individual Urgency Alerts.

DSC SETUP

► To enable/disable the channel change:

1. From the DSC SETUP menu item described on *page 71*, rotate the **CH** knob until the arrow points to AUTO CH CHG.

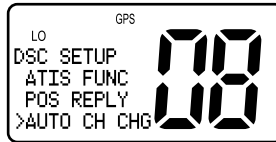
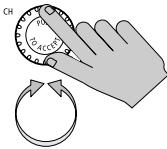

2. Press the **CH** knob to accept.

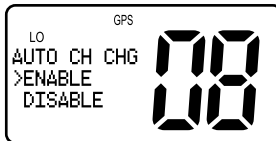

Procedure When Enabled

If you accept ENABLE, your Ray54E automatically changes to channel 16 when a Distress or All Ships Urgency Call is received, as described in *Chapter 5*:

Procedure When Disabled

If you accept DISABLE, on receipt of a Distress or All Ships Urgency Call you are presented with brief details of the call and advised that a change to channel 16 has been requested. You can either accept the channel change by pressing **ACCEPT** (CH knob) or decline by pressing **CLEAR**, thereby continuing to monitor your current channel.

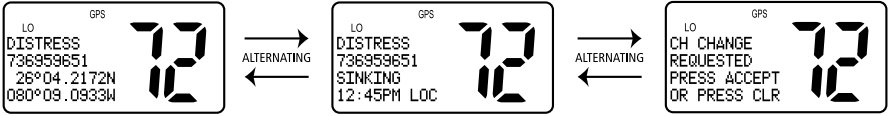

If you accept the request, the call is received, a tone sounds and the radio is changed to channel 16. Pressing any key disables the alarm. When position and time data is included in the signal, it is displayed in the text area of the LCD. If invalid GPS or Time data is received, the lat/lon position shows 9s in all digits and all 8s for the time. The two alternating pages of data are recorded in the Distress Call Log regardless of whether or not you accept the call.

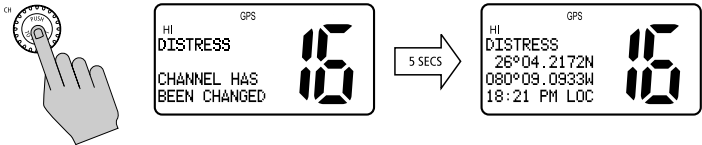

If you ignore the call, after 5 minutes the radio declines the call, records the call in the Call Log and maintains normal operation.

6.9 Resetting Factory Defaults

This feature returns all radio settings to their factory defaults, including BACKLIGHT, CONTRAST, RING VOLUME, KEY BEEP and manual GPS/TIME settings. MY MMSI ID number, MY ATIS ID number, CH NAME and the PHONEBOOK are not affected.

RESET

➤ To perform the reset:

1. **Press and hold** the **CALL/MENU** key to enter Menu mode.

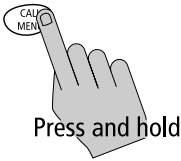

2. Rotate the **CH** knob to scroll down the list until the arrow points to **RESET**.

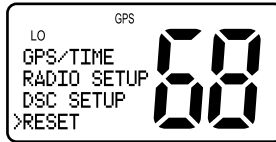
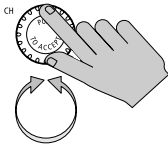

3. Press the **CH** knob to accept. The Reset screen appears.

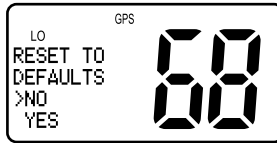

4. Rotate the **CH** knob until arrow points to **YES**.

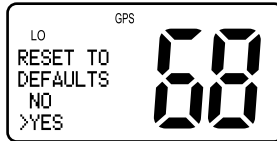
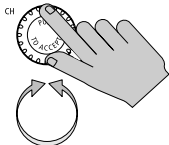

5. Press the **CH** knob to accept.

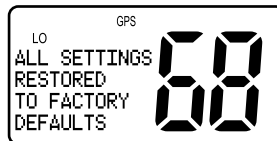

Chapter 7: Customer Service

This chapter provides information on service for your Ray54E.

7.1 How to Contact Raymarine

On the Internet

Visit the Raymarine World Wide Web site for the latest information on Raymarine electronic equipment and systems at:

www.raymarine.com

Customer Support

Navigate to the **Customer Support** page for links for:

- Finding Factory Service locations and Authorized Dealers near you
- Registering your Raymarine products
- Accessing handbooks in Adobe Acrobat format
- Downloading RayTech software updates
- Accessing the Raymarine solution database

Clicking the **Find Answers** link routes you to our solution database. Search questions and answers by product, category, keywords, or phrases. If the answer you are seeking is not available, click the **Ask Raymarine** tab to submit your own question to our technical support staff, who will reply to you by e-mail.

In Europe

In Europe, Raymarine support, service and accessories may be obtained from your authorized dealer, or contact:

Raymarine Ltd
Anchorage Park
Portsmouth, Hampshire
England PO3 5TD
Tel: +44 (0) 23 9269 3611
Fax: +44 (0) 23 9269 4642

Technical Support

The Technical Services Department handles inquiries concerning installation, operation, fault diagnosis and repair. For technical helpdesk contact:

Tel: +44 (0) 23 9271 4713

Fax: +44 (0) 23 9266 1228

Accessories and Parts

Raymarine accessory items and parts are available through your authorized Raymarine distributor. Please refer to the lists of component part numbers and optional accessories in the Installation chapter of this manual and have the Raymarine part number ready when speaking with your dealer.

If you are uncertain about what item to choose for your unit, please contact our Customer Services Department prior to placing your order.

Worldwide Support

Please contact the authorized distributor in the country.

Appendix A: Specifications

General

Size (H x W x D)	3.11" (79 mm) x 6.57" (167 mm) x 6.73" (171mm)
Weight	2.87 lbs (1.3kg)
Mounting	Bracket or flush mount
Power	13.6 VDC \pm 15%
Environmental: Operating Range: Storage Range: Humidity:	Waterproof to IPX7 -15°C to +55°C -20°C to +70°C up to 95%
Frequency Range: Transmit Receive	156.050 To 157.425 MHz 156.050 To 163.275 MHz
Channels	All available International VHF Marine Band. US and Canadian channels also available if so programmed.
Oscillate Mode	PLL
Modulation	FM(16K0G3E) DSC(16K0G2B)
Channel Spacing	25 kHz Increments
Frequency Stability	+/- 10PPM (+/- 0.001%)

Receiver

Intermediate Frequency:		
1st		21.4 MHz
2nd		455 KHz
Sensitivity		0.25 μ V (12dB SINAD)
Squelch Sensitivity		> 0.7 μ V at tight
Spurious Response Rejection Ratio		70 dB
Adjacent Channel Selectivity		70 dB
Intermodulation Rejection Ratio		68dB
S/N at 3KHz Dev.		40 dB
Audio Output Power At THD 10%		2 W
Audio Distortion		10%
Current Drain at:		
Max Audio Power		1.5 A
Stand-By		0.5 A

Transmitter

RF Power:		
Hi Mode		23 \pm 2 W
Lo Mode		0.8 \pm 0.1 W
Maximum Deviation		\pm 5 KHz
S/N at 3KHz Dev		40 dB
Modulation Distortion		3KHz \leq 7%
Audio Response		1KHz EIA STANDARD dB
Spurious/Harmonic Emissions:		0.25 μ W
Modulation Sensitivity		\leq 12mv
Current Drain At 13.6V DC:		
Hi Power		\leq 6 A
Lo Power		\leq 1.5A

Appendix B: Channel List

International Marine VHF Channels & Frequencies

CH No.	XMIT Freq	RCV Freq	Single Freq	Use
01	156.050	160.650		Public Correspondence, Port Operations and Ship Movement
02	156.100	160.700		Public Correspondence, Port Operations and Ship Movement
03	156.150	160.750		Public Correspondence, Port Operations and Ship Movement
04	156.200	160.800		Public Correspondence, Port Operations and Ship Movement
05	156.250	160.850		Public Correspondence, Port Operations and Ship Movement
06	156.300	156.300	x	Intership ¹
07	156.350	160.950		Public Correspondence, Port Operations and Ship Movement
08	156.400	156.400	x	Intership
09	156.450	156.450	x	Intership, Port Operations and Ship Movement
10	156.500	156.500	x	Intership, Port Operations and Ship Movement ²
11	156.550	156.550	x	Port Operations and Ship Movement
12	156.600	156.600	x	Port Operations and Ship Movement
13	156.650	156.650	x	Intership Safety, Port Operations and Ship Movement ³
14	156.700	156.700	x	Port Operations and Ship Movement
15	156.750	156.750	x	Intership and On-board Communications at 1W only ⁴
16	156.800	156.800	x	Distress, Safety and Calling
17	156.850	156.850	x	Intership and On-board Communications at 1W only ⁴
18	156.900	161.500		Public Correspondence
19	156.950	161.550		Public Correspondence, Port Operations and Ship Movement
20	157.000	161.600		Public Correspondence, Port Operations and Ship Movement
21	157.050	161.650		Public Correspondence, Port Operations and Ship Movement
22	157.100	161.700		Public Correspondence, Port Operations and Ship Movement
23	157.150	161.750		Public Correspondence, Port Operations and Ship Movement

CH No.	XMIT Freq	RCV Freq	Single Freq	Use
24	157.200	161.800		Public Correspondence, Port Operations and Ship Movement
25	157.250	161.850		Public Correspondence, Port Operations and Ship Movement
26	157.300	161.900		Public Correspondence, Port Operations and Ship Movement
27	157.350	161.950		Public Correspondence, Port Operations and Ship Movement
28	157.400	162.000		Public Correspondence, Port Operations and Ship Movement
60	156.025	160.625		Public Correspondence, Port Operations and Ship Movement
61	156.075	160.675		Public Correspondence, Port Operations and Ship Movement
62	156.125	160.725		Public Correspondence, Port Operations and Ship Movement
63	156.175	160.775		Public Correspondence, Port Operations and Ship Movement
64	156.225	160.825		Public Correspondence, Port Operations and Ship Movement
65	156.275	160.875		Public Correspondence, Port Operations and Ship Movement
66	156.325	160.925		Public Correspondence, Port Operations and Ship Movement
67	156.375	156.375	x	Intership, Port Operations and Ship Movement
68	156.425	156.425	x	Port Operations and Ship Movement
69	156.475	156.475	x	Port Operations and Ship Movement
71	156.575	156.575	x	Port Operations and Ship Movement
72	156.625	156.625	x	Intership
73	156.675	156.675	x	Intership ²
74	156.725	156.725	x	Port operations and Ship movement
75	156.775	156.775	x	See Note 5
76	156.825	156.825	x	See Note 5
77	156.875	156.875	x	Intership
78	156.925	161.525		Public correspondence, Port Operations and Ship Movement
79	156.975	161.575		Public correspondence, Port Operations and Ship Movement
80	157.025	161.625		Public correspondence, Port Operations and Ship Movement
81	157.075	161.675		Public correspondence, Port Operations and Ship Movement

CH No.	XMIT Freq	RCV Freq	Single Freq	Use
82	157.125	161.725	x	Public correspondence, Port Operations and Ship Movement
83	157.175	161.775	x	Public correspondence, Port Operations and Ship Movement
84	157.225	161.825	x	Public correspondence, Port Operations and Ship Movement
85	157.275	161.875	x	Public correspondence, Port Operations and Ship Movement
86	157.325	161.925	x	Public correspondence, Port Operations and Ship Movement
87	157.375	157.375	x	Port Operations and Ship Movement
88	157.425	157.425	x	Port Operations and Ship Movement

- Intership channels are for communications between ship stations. Intership communications should be restricted to Channels 6, 8, 72 and 77. If these are not available, the other channels marked for Intership may be used.
- Channels 10, 67 and 73 should be avoided within VHF range of coastal areas in Europe and Canada.
- Channel 70 is used exclusively for Digital Selective Calling (DSC) and is not available for regular voice communications.

Notes:

1. Channel 06 may also be used for communications between ship stations and aircraft engaged in coordinated search and rescue operations. Ship stations should avoid harmful interference to such communications on channel 06 as well as to communications between aircraft stations, ice breakers and assisted ships during ice seasons.
2. Channels 10 or 73 (depending on location) are also used for the broadcast of Marine Safety Information by the Maritime and Coast Guard Agency in the UK only.
3. Channel 13 is designated for use on a worldwide basis as a navigation safety communication channel, primarily for intership navigation safety communications.
4. Channels 15 and 17 may also be used for on-board communications provided the effective radiated power does not exceed 1 Watt.
5. The use of Channels 75 and 76 should be restricted to navigation related communication only and all precautions should be taken to avoid harmful interference to channel 16. Transmit power is limited to 1 Watt.

European Private Channels and Frequencies

Country	Channel Number	TX Freq	RX Freq	Channel Use
Belgium	31	157.550	162.150	n/a
	96	162.425	162.425	n/a
Denmark	L1	155.500	155.500	Pleasure Boat
	L2	155.525	155.525	Pleasure Boat
Denmark, Finland, Norway & Sweden	F1	155.625	155.625	Fishing Boat
	F2	155.775	155.775	Fishing Boat
	F3	155.825	155.825	Fishing Boat
Finland, Norway & Sweden	L1	155.500	155.500	Pleasure Boat
	L2	155.525	155.525	Pleasure Boat
	L3	155.650	155.650	Pleasure Boat
Netherlands	31	157.550	162.150	n/a
	37	157.850	157.850	n/a
UK	M1	157.850	157.850	Pleasure Boat
	M2	161.425	161.425	Pleasure Boat

Note: A licence may be required to operate the radio on the private channels. It is your responsibility to obtain the proper licence to operate the radio on these frequencies.

WX Channels (North America only)

Weather Channel	Frequency in MHz	Weather Channel	Frequency in MHz
WX 1	162.550	WX 6	162.500
WX 2	162.400	WX 7	162.525
WX 3	162.475	WX 8	161.650
WX 4	162.425	WX 9	161.775
WX 5	162.450	WX 10	163.275

U.S. Marine VHF Channels and Frequencies

CH. No	XMIT Freq	RCV Freq	Single Freq	Use
01A	156.050	156.050	x	Port Operations and Commercial, VTS. Available only in New Orleans / Lower Mississippi area. ¹
03A	156.150	156.150	x	U.S. Government only
05A	156.250	156.250	x	Port Operations or VTS in the Houston, New Orleans and Seattle areas.
06	156.300	156.300	x	Intership Safety
07A	156.350	156.350	x	Commercial
08	156.400	156.400	x	Commercial (Intership only)
09	156.450	156.450	x	Boater Calling. Commercial and Non-Commercial.
10	156.500	156.500	x	Commercial
11	156.550	156.550	x	Commercial. VTS in selected areas.
12	156.600	156.600	x	Port Operations. VTS in selected areas.
13	156.650	156.650	x	Intership Navigation Safety (Bridge-to-bridge). Ships >20meters in length maintain a listening watch on this channel in US waters. ^{2,6}
14	156.700	156.700	x	Port Operations. VTS in selected areas.
15	-	156.750	x	Environmental (Receive only). Used by Class 'C' EPIRBs. ³
16	156.800	156.800	x	International Distress, Safety and Calling. Ships required to carry radio, USCG, and most coast stations maintain a listening watch on this channel. ⁴
17	156.850	156.850	x	State Control ⁵
18A	156.900	156.900	x	Commercial
19A	156.950	156.950	x	Commercial
20	157.000	161.600		Port Operations (duplex)
20A	157.000	157.000	x	Port Operations
21A	157.050	157.050	x	U.S. Coast Guard only
22A	157.100	157.100	x	Coast Guard Liaison and Maritime Safety Information Broadcasts. Broadcasts announced on channel 16.

CH. No	XMIT Freq	RCV Freq	Single Freq	Use
23A	157.150	157.150	x	U.S. Coast Guard only
24	157.200	161.800		Public Correspondence (Marine Operator)
25	157.250	161.850		Public Correspondence (Marine Operator)
26	157.300	161.900		Public Correspondence (Marine Operator)
27	157.350	161.950		Public Correspondence (Marine Operator)
28	157.400	162.000		Public Correspondence (Marine Operator)
61A	156.075	156.075	x	U.S. Government only
63A	156.175	156.175	x	Port Operations and Commercial, VTS. Available only in New Orleans / Lower Mississippi area.
64A	156.225	156.225	x	U.S. Coast Guard only
65A	156.275	156.275	x	Port Operations
66A	156.325	156.325	x	Port Operations
67	156.375	156.375	x	Commercial. Used for Bridge-to-bridge communications in lower Mississippi River. Intership only. ⁶
68	156.425	156.425	x	Non-Commercial
69	156.475	156.475	x	Non-Commercial
71	156.575	156.575	x	Non-Commercial
72	156.625	156.625	x	Non-Commercial (Intership only)
73	156.675	156.675	x	Port Operations
74	156.725	156.725	x	Port Operations
77	156.875	156.875	x	Port Operations (Intership only) ⁵
78A	156.925	156.925	x	Non-Commercial
79A	156.975	156.975	x	Commercial. Non-Commercial in Great Lakes only.
80A	157.025	157.025	x	Commercial. Non-Commercial in Great Lakes only
81A	157.075	157.075	x	U.S. Government only – Environmental protection operations.
82A	157.125	157.125	x	U.S. Government only
83A	157.175	157.175	x	U.S. Coast Guard only

CH. No	XMIT Freq	RCV Freq	Single Freq	Use
84	157.225	161.825		Public Correspondence (Marine Operator)
85	157.275	161.875		Public Correspondence (Marine Operator)
86	157.325	161.925		Public Correspondence (Marine Operator)
87	157.375	161.975		Public Correspondence Marine Operator)
88	157.425	162.025		Public Correspondence only near Canadian border
88A	157.425	157.425	x	Commercial, Intership only

- Recreational boaters normally use channels listed as Non-Commercial: 68, 69, 71, 72, 78A.
- Channel 70 is used exclusively for Digital Selective Calling (DSC) and is not available for regular voice communications.
- Channels 75 and 76 are reserved as guard bands for Channel 16 and are not available for regular voice communications.

Notes:

1. The letter "A" following a channel number indicates simplex use of the ship station transmit side of an international duplex channel. Operations are different from that of international operations on that channel.
2. Channel 13 should be used to contact a ship when there is danger of collision. All ships of length 20 meters or greater are required to guard VHF channel 13, in addition to VHF channel 16, when operating within U.S. territorial waters.
3. Channel is Receive Only.
4. Channel 16 is used for calling other stations or for distress alerting.
5. Output power is fixed at 1 watt only.
6. Output power is initially set to 1 watt. User can temporarily override this restriction to transmit at high power.

Canadian Marine VHF Channels and Frequencies

CH No.	XMIT Freq	RCV Freq	Area of Operation	Use
01	156.050	160.650	PC	Public Correspondence
02	156.100	160.700	PC	Public Correspondence
03	156.150	160.750	PC	Public Correspondence
04A	156.200	156.200	PC	Intership, Ship/Shore and Safety: Canadian Coast Guard search and rescue ¹
04A	156.200	156.200	EC	Intership, Ship/Shore and Commercial: Commercial fishing only
05A	156.250	156.250		Ship Movement
06	156.300	156.300	All areas	Intership, Commercial, Non-commercial and Safety: May be used for search and rescue communications between ships and aircraft.
07A	156.350	156.350	All areas	Intership, Ship/Shore, Commercial
08	156.400	156.400	WC, EC	Intership, Commercial and Safety: Also assigned for operations in the Lake Winnipeg area.
09	156.450	156.450	AC	Intership, Ship/Shore, Commercial, Non-commercial and Ship Movement: May be used to communicate with aircraft and helicopters in predominantly maritime support operations.
10	156.500	156.500	AC, GL	Intership, Ship/Shore, Commercial, Non-commercial, Safety and Ship Movement: May also be used for communications with aircraft engaged in coordinated search and rescue and antipollution operations.
11	156.550	156.550	PC, AC, GL	Intership, Ship/Shore, Commercial, Non-commercial and Ship Movement: Also used for pilotage purposes.
12	156.600	156.600	WC, AC, GL	Intership, Ship/Shore, Commercial, Non-commercial and Ship Movement: Port operations and pilot information and messages.
13	156.650	156.650	All areas	Intership, Commercial, Non-commercial and Ship Movement: Exclusively for bridge-to-bridge navigational traffic. Limited to 1-watt maximum power.
14	156.700	156.700	AC, GL	Intership, Ship/Shore, Commercial, Non-commercial and Ship Movement: Port operations and pilot information and messages.

CH No.	XMIT Freq	RCV Freq	Area of Operation	Use
15	156.750	156.750	All areas	Intership, Ship/Shore, Commercial, Non-commercial and Ship Movement: All operations limited to 1-watt maximum power. May also be used for on-board communications.
16	156.800	156.800	All areas	International Distress, Safety and Calling ²
17	156.850	156.850	All areas	Intership, Ship/Shore, Commercial, Non-commercial and Ship Movement: All operations limited to 1-watt maximum power. May also be used for on-board communications.
18A	156.900	156.900	All areas	Intership, Ship/Shore and Commercial: Towing on the Pacific Coast.
19A	156.950	156.950	All areas except PC	Intership and Ship/Shore: Canadian Coast Guard only.
19A	156.950	156.950	PC	Intership and Ship/Shore: Various Government departments.
20	157.000	161.600	All areas	Ship/Shore, Safety and Ship Movement: Port operations only with 1-watt maximum power.
21A	157.050	157.050	All areas	Intership and Ship/Shore: Canadian Coast Guard only.
21B	-	161.650	All areas	Safety: Continuous Marine Broadcast (CMB) service. ³
22A	157.100	157.100	All areas	Intership, Ship/Shore, Commercial and Non-commercial: For communications between Canadian Coast Guard and non-Canadian Coast Guard stations only.
23	157.150	161.750	PC	Ship/Shore and Public Correspondence: Also in the inland waters of British Columbia and the Yukon.
24	157.200	161.800	All areas	Ship/Shore and Public Correspondence
25	157.250	161.850	PC	Ship/Shore and Public Correspondence: Also assigned for operations in the Lake Winnipeg area.
25B	-	161.850	AC	Safety: Continuous Marine Broadcast (CMB) service.
26	157.300	161.900	All areas	Ship/Shore, Safety and Public Correspondence
27	157.350	161.950	AC, GL, PC	Ship/Shore and Public Correspondence
28	157.400	162.000	PC	Ship/Shore, Safety and Public Correspondence
28B	-	162.000	AC	Safety: Continuous Marine Broadcast (CMB) service.

CH No.	XMIT Freq	RCV Freq	Area of Operation	Use
60	156.025	160.625	PC	Ship/Shore and Public Correspondence
61A	156.075	156.075	PC	Intership and Ship/Shore: Canadian Coast Guard only.
61A	156.075	156.075	EC	Intership, Ship/Shore and Commercial: Commercial fishing only.
62A	156.125	156.125	PC	Intership and Ship/Shore: Canadian Coast Guard only.
62A	156.125	156.125	EC	Intership, Ship/Shore and Commercial: Commercial fishing only.
64	156.225	160.825	PC	Ship/Shore and Public Correspondence
64A	156.225	156.225	EC	Intership, Ship/Shore and Commercial: Commercial fishing only.
65A	156.275	156.275		Intership, Ship/Shore, Commercial, Non-commercial, Safety: Search & rescue and antipollution operations on the Great Lakes. Towing on the Pacific Coast. Port operations only in the St. Lawrence River areas with 1W maximum power. Pleasure craft in the inland waters of Alberta, Saskatchewan and Manitoba (excluding Lake Winnipeg and the Red River).
66A	156.325	156.325		Intership, Ship/Shore, Commercial, Non-commercial, Safety and Ship Movement: Port operations only in the St. Lawrence River/Great Lakes Areas with 1-watt maximum power.
67	156.375	156.375	EC	Intership, Ship/Shore and Commercial: Commercial fishing only.
67	156.375	156.375	All areas except EC	Intership, Ship/Shore, Commercial, Non-commercial, Safety: May also be used for communications with aircraft engaged in coordinated search and rescue and antipollution operations.
68	156.425	156.425	All areas	Intership, Ship/Shore and Non-commercial: For marinas and yacht clubs.
69	156.475	156.475	All areas except EC	Intership, Ship/Shore, Commercial and Non-commercial
69	156.475	156.475	EC	Intership, Ship/Shore and Commercial: Commercial fishing only
71	156.575	156.575	PC	Intership, Ship/Shore, Commercial, Non-commercial, Safety and Ship Movement

CH No.	XMIT Freq	RCV Freq	Area of Operation	Use
71	156.575	156.575		Intership, Ship/Shore and Non-commercial: For marinas and yacht clubs on the East Coast and on Lake Winnipeg.
72	156.625	156.625	EC, PC	Intership, Commercial and Non-commercial: May be used to communicate with aircraft and helicopters in predominantly maritime support operations.
73	156.675	156.675	EC	Intership, Ship/Shore and Commercial: Commercial fishing only
73	156.675	156.675	All areas except EC	Intership, Ship/Shore, Commercial, Non-commercial, Safety: May also be used for communications with aircraft engaged in coordinated search and rescue and antipollution operations.
74	156.725	156.725	EC, PC	Intership, Ship/Shore, Commercial, Non-commercial and Ship Movement
77	156.875	156.875		Intership, Ship/Shore, Safety and Ship Movement: Pilotage on Pacific Coast. Port operations only in the St. Lawrence River/Great Lakes areas with 1W maximum power.
78A	156.925	156.925	EC, PC	Intership, Ship/Shore and Commercial
79A	156.975	156.975	EC, PC	Intership, Ship/Shore and Commercial
80A	157.025	157.025	EC, PC	Intership, Ship/Shore and Commercial
81A	157.075	157.075		Intership and Ship/Shore: Canadian Coast Guard use only in the St. Lawrence River/Great Lakes areas.
81A	157.075	157.075	PC	Intership, Ship/Shore and Safety: Canadian Coast Guard antipollution.
82A	157.125	157.125	PC	Intership, Ship/Shore and Safety: Canadian Coast Guard use only.
82A	157.125	157.125		Intership and Ship/Shore: Canadian Coast Guard use only in the St. Lawrence River/Great Lakes areas.
83	157.175	161.775	PC	Ship/Shore and Safety: Canadian Coast Guard use only.
83A	157.175	157.175	EC	Intership and Ship/Shore: Canadian Coast Guard and other Government agencies.
83B	-	161.775	AC, GL	Safety: Continuous Marine Broadcast (CMB) Service.
84	157.225	161.825	PC	Ship/Shore and Public Correspondence

CH No.	XMIT Freq	RCV Freq	Area of Operation	Use
85	157.275	161.875	AC, GL, NL	Ship/Shore and Public Correspondence
86	157.325	161.925	PC	Ship/Shore and Public Correspondence
87	157.375	161.975	AC, GL, NL	Ship/Shore and Public Correspondence
88	157.425	162.025	AC, GL, NL	Ship/Shore and Public Correspondence

Area of Operation

AC: Atlantic Coast, Gulf and St. Lawrence River up to and including Montreal

EC (East Coast): includes NL, AC, GL and Eastern Arctic areas

GL: Great Lakes (including St. Lawrence above Montreal)

NL: Newfoundland and Labrador

PC: Pacific Coast

WC (West Coast): Pacific Coast, Western Arctic and Athabasca-Mackenzie Watershed areas

All areas: includes East and West Coast areas

Notes:

1. The letter "A" following a channel number indicates simplex use of the ship station transmit side of an international duplex channel. Operations are different from that of international operations on that channel.
2. Channel 16 is used for calling other stations or for distress alerting.
3. The letter "B" following a channel number indicates simplex use of the coast station transmit side of an international duplex channel. That is, the channel is Receive Only.
4. Channel 70 is used exclusively for Digital Selective Calling (DSC) and is not available for regular voice communications.
5. Channels 75 and 76 are reserved as guard bands for Channel 16 and are not available for regular voice communications.

Appendix C: Glossary

Term	Meaning
All Scan	A feature that scans all channels.
ATIS	Automatic Transmitter Identification System. Used for inland waterways in some European countries.
Canadian Channels	Channel designator as defined by Industry Canada.
CH	Channel selection key
DSC	Digital Selective Calling
Dual Watch	A feature that monitors the Priority Channel 16 while working on another channel.
Duplex	Transmit and receive on different frequencies
FCC	Federal Communications Commission (US)
International Channels	Channel designator as defined by the ITU
ITU	International Telecommunications Union (EU)
LCD	Liquid Crystal Display
MMSI	Maritime Mobile Service Identity; a number issued by each country to identify maritime stations
NOAA	National Oceanographic and Atmospheric Administration (USA)
Priority Channel	Channel 16
Priority Scan (PSCAN)	A feature that alternates monitoring the Priority Channel 16 with each of the regular channels
PTT switch	Microphone push-to-talk switch
RF	Radio Frequency
RTCM	Radio Technical Commission for Maritime Services
RX	Receive
Saved Scan	Scans only user-selected memory channels
Simplex	Transmit and receive on the same frequency
Squelch	A circuit that sets the threshold for cutting off the receiver when the signal is too weak for reception of anything but noise.
TX	Transmit

Term	Meaning
Tri Watch	A function that monitors the Priority Channel and the Favourite (PLUS) Channel while working on another channel.
US Channels	Channel designations as defined by the FCC.
VOL	Volume key
VHF	Very High Frequency (30MHz to 300MHz)
Weather (WX) Channels	Channels for routine and emergency weather information broadcast by NOAA (USA).
Working Channel	The currently-selected (non-priority, non-WX) channel.

Index

Symbols

- "A" indicator 16
- "B" indicator 16
- "C" indicator 16
- "I" indicator 16
- "U" indicator 16
- "UC" indicator 54

Numerics

- 16/PLUS key 11, 14

A

- Adding channels to memory 26
- ALERT indicator 15
- All Scan function 24
- All Ships Calls 42
 - Receiving 43
 - Urgency 42
- ATIS 77
- ATIS Function 79
- ATIS indicator 15
- Auto Channel Changing 82

B

- Backlight adjustment 63
- Battery Low 15

C

- Call Mode
 - All Ships Calls 42
 - Distress Calls 45
 - Group Calls 38
 - Individual Calls 34
- CALL/MENU key 12, 32, 57
- Canadian channels 96
- CH indicator 16
- Channel List
 - Canadian frequencies 96
 - International frequencies 89
 - US frequencies 93
 - WX frequencies 92
- Channel Name 70
 - Deleting entries 70

- Channel setting 18
- Channel UP/DOWN key 11
- CLEAR Key 14
- COG/SOG Display 68
- Contrast adjustment 63
- Conventions iii
- Customer Support 85

D

- Delete channels from memory 26
- Distress Calls 45
 - Receiving 48
 - Receiving Acknowledgement 49
 - Receiving Distress Relay 49
 - Sending a Designated call 46
 - Sending an Undesignated (QUICK) call 45
- Distress key 14
- DSC Calls 32
- DSC Message indicator 15
- DSC Phonebook 59
- DSC Settings
 - ATIS Function 79
 - Auto Channel Changing 82
 - Group MMSI Setup 73
 - My ATIS ID 77
 - My MMSI ID 72
 - Position Reply 81
- Dual Watch 11, 27
- DW/TRI key 11

E

- Excessive Voltage 6

F

- Favourite (PLUS) Channel 21
- Features 1
- Frequency Band 69
 - Canadian channels 96
 - International channels 89
 - US channels 93
 - WX channels 92

G

- Glossary 101
- GPS
 - indicator 15

- Installing 7
- Position Reply 81
 - setup 64
- Group Calls 38
 - Receiving 40
 - Transmitting 38
- Group MMSI Setup 73

H

- Help from Raymarine 85
- HI/LO
 - indicator 14
 - key 11
 - power selection 13, 17
- HL/USER key 13

I

- Individual Calls 34
 - Receiving 37
 - Sent using the Phonebook 34

- Installation 3
- International channels 89
- Invalid Channel 38, 41, 44

K

- Key Beep 70
- Keypad 9

L

- Last Received Position Request 52
- Latitude/Longitude Display 67
- LCD display 14

M

- Memory
 - Adding channels 26
- Menu 12
- Menu Mode 57
 - Backlight adjustment 63
 - Contrast adjustment 63
 - DSC Setup 71
 - GPS/Time Setup 64
 - Phonebook 59
 - Adding entries 59
 - Deleting entries 62
 - Editing entries 61
 - Radio Setup 69

- Reset 84
- Settings 66

- MMSI 72
- Monitor Mode 27
 - Dual Watch 27
 - Tri Watch 28
- My ATIS ID 77
- My MMSI ID 72

O

- Optional equipment 3

P

- Phonebook 59
 - Adding entries 59
 - Deleting entries 62
 - Editing entries 61
- Position Reply 81
- Position Request 50
 - from Phonebook 50
 - Receiving from another station 53
 - Retrieving Last Received 52

Power 11

- ON/OFF 17
- selection 17

- Priority Channel 20
- Priority Saved Scan function 25
- Priority Scan function 25
- PTT key 11, 23
- Push-to-Talk key 23
- PWR/VOL key 11

R

- Radio Setup 69
 - Channel Name 70
 - Frequency Band 69
 - Key Beep 70
 - Ring Volume 70
- Raymarine
 - Website 85
- Reset 84
- Ring Volume 70
- RX indicator 15

S

- Save 13
- SAVED indicator 15

-
- Saved Scan function 24
 - Scan Mode 23
 - All Scan 24
 - Priority All Scan 25
 - Priority Saved Scan 25
 - Saved Scan 24
 - SCAN/SAVE key 13
 - Secondary Priority Channel 21
 - Settings 66, 71
 - COG/SOG Display 68
 - Latitude/Longitude Display 67
 - Time Display 67
 - Time Format 68
 - Time Offset 68
 - Specifications 87
 - SQ key 11
 - Squelch 11, 17
 - Standard equipment 3
 - T**
 - Time Display 67
 - Time Format 68
 - Time Offset 68
 - Time Setup 64
 - Transmitting 23
 - indicator 14
 - Tri Watch 11, 28
 - TX 23
 - TX indicator 14
 - U**
 - Unable to Comply 38, 41, 44, 54
 - US channels 93
 - USER Channel Mode 11, 29
 - indicator 15
 - key 13
 - UTC time setup 64
 - V**
 - Voltage
 - high 6
 - low 6, 15
 - Volume 11, 17
 - W**
 - Warranty iii
 - Weather Alert 20
 - Weather Channels 19
 - Website 85
 - WX 19
 - channels 92
 - indicator 15

